

Marshall

BROADCAST & PRO AV

CV620-BK4/WH4

Full-HD PTZ Camera

Installation Guide



Table of Contents

Safety Instructions	4
Package Contents	6
Product Overview	7
3.1 Overview.....	7
3.2 Description of LED indicator.....	7
Instruction for Installation	8
4.1 Preparation before installation.....	8
4.2 Instruction for installation.....	8
4.3 Connecting the device	17
Remote Control and Setting Menu	19
5.1 Functions of remote control.....	19
5.2 Setting Menu	20
Descriptions of Major Functions	29
6.1 I would like to switch to CV620-BK2/WH2	29
6.2 I would like to save the current lens position data.....	29
6.3 I would like to clear the saved position data.....	29
6.4 I would like to turn on the back light compensation function.....	29
6.5 I would like to adjust the shooting angle of the lens.....	29
6.6 I would like to hide the preset image switch (Motionless Preset).....	29
6.7 I would like to zoom in/out images	30
6.8 I would like to adjust the focal length.....	30
6.9 I would like to adjust the AF sensitivity	30
6.10 I would like to set the image mode	31
6.11 I would like to freeze images	31
6.12 I would like to rotate the image.....	31

6.13 I would like to change the camera direction	31
6.14 I would like to display the current status.....	31
6.15 I would like to reset to the original setting	31
DIP Switch Setting.....	32
7.1 DIP Switch	32
7.2 RS-422 Connection	33
Troubleshooting	35

Page intentionally left blank

Safety Instructions

Always follow these safety instructions when setting up and using the Camera:

1. Use attachments only as recommended.
2. Use the type of power source indicated on the Camera. If you are not sure of the type of power available, consult your distributor or local electricity company for advice.
3. Always take the following precautions when handling the plug. Failure to do so may result in sparks or fire:
 - Ensure the plug is free of dust before inserting it into a socket.
 - Ensure that the plug is inserted into the socket securely.
4. Do not overload wall sockets, extension leads or multi-way plug boards to avoid potential risks.
5. Do not place the Camera where the cord can be stepped on as this may result in fraying or damage to the lead or the plug.
6. Do not block the slots and openings in the case of this Camera. They provide ventilation and prevent the Camera from overheating. Do not place the Camera on the soft surfaces of sofas, carpets, or other similar surface.
7. Never push objects of any kind through cabinet slots. Never allow liquid of any kind to spill into the Camera.
8. Except as specifically instructed in this User Manual, do not attempt to operate this product by yourself. Opening or removing covers may expose you to dangerous voltages and other hazards. Refer all servicing to licensed service personnel.
9. Unplug the Camera during thunderstorms or if it is not going to be used for an extended period. Do not place the Camera or remote control on top of vibrating equipment or heated objects such as a car, etc.
10. Unplug the Camera from the wall outlet and refer servicing to licensed service personnel when the following situations happen:
 - If the power cable or plug becomes damaged or frayed.
 - If the Camera is wet with liquid, rain, or water.





*Note

Using an incorrect battery type in the remote control may result in breakdown. Follow local instructions on how to dispose of used batteries

■ Precautions

Warning: To reduce the risk of fire or electric shock, do not expose this camera to rain or moisture.

If Camera will not be used for an extended time, unplug it from the power socket.

	<table border="1"> <tr><td style="text-align: center;">Note</td></tr> <tr><td style="text-align: center;">Risk of Electric Shock Please do not open it by yourself.</td></tr> </table>	Note	Risk of Electric Shock Please do not open it by yourself.	
Note				
Risk of Electric Shock Please do not open it by yourself.				
<p>Caution: To reduce the risk of electric shock, do not remove cover (or back). No user-serviceable parts inside. Refer servicing to licensed service personnel.</p>				
	<p>This symbol indicates that this equipment may contain dangerous voltage which could cause electric shock.</p>		<p>This symbol indicates that there are important operating and maintenance instructions in this User Manual with this unit.</p>	

■ FCC Warning

This HD camera has been tested and found to comply with the limits for a Class A digital device, pursuant to Article 15-J of FCC Rules. These limits are designed to provide reasonable protection against harmful interference in a commercial installation.

This digital apparatus does not exceed the Class A limits for radio noise emissions from digital apparatus as set out in the interference-causing equipment standard entitled "Digital Apparatus," ICES-003 of Industry Canada.

Cet appareil numérique respecte les limites de bruits radioélectriques applicables aux appareils numériques de Classe A prescrites dans la norme sur le matériel brouilleur: "Appareils Numériques," NMB-003 édictée par l'Industrie.

■ EN55032 (CE Radiation) Warning

Operation of this equipment in a residential environment could cause radio interference.

Chapter 2 Package Contents

CV620-BK4/WH4



Instructions for
installation



Remote Control



Power Cord



Appearance may vary
depending on
country/region

Power Adapter



RS-422 Connector



Metal Plate A

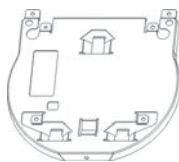

Metal Plate B

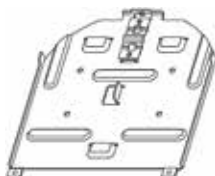

M3 Screws



Chapter 3 Product Overview

3.1 Overview

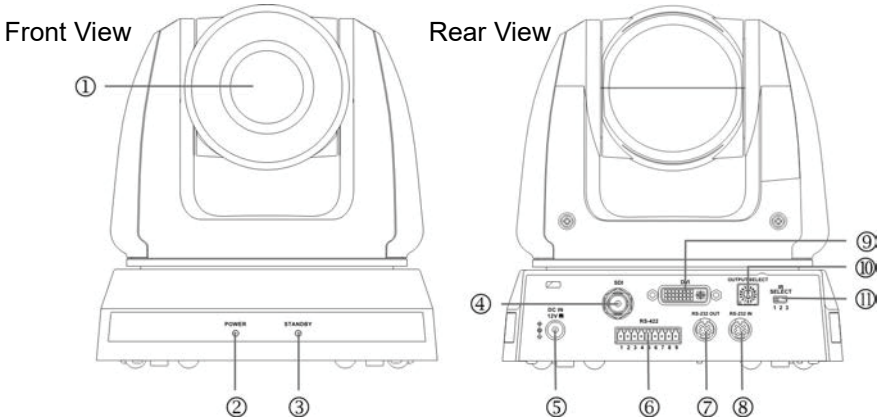

1. Camera Lens	2. Power LED Indicator
3. Standby LED Indicator	4. 3G-SDI Output
5. Power Input	6. RS-422 Connection
7. RS-232 Output	8. RS-232 Input
9. DVI Output	10. OUTPUT Switch
11. IR SELECT	

3.2 Description of LED indicator

3.2.1 Power :

3.2.1.1 No Light: Power off

3.2.1.2 Green light: In use

3.2.1.3 Flickering green: Signal from the remote control is received;
the indicator flickers every 0.5 seconds

3.2.2 Standby :

3.2.2.1 Orange: In standby mode

3.2.2.2 No Light: Power on

Instruction for Installation

4.1 Preparation before installation

Installation and connection of the Camera requires special skills. To install by yourself, please follow necessary steps, ensure steady and tight installation of the device, and pay attention to your safety to avoid any accident.

- 4.1.1 Ensure the safety of the installation environment. Please do not install this device on an unstable ceiling or in a place where the device is in danger of falling to avoid any accident.**
- 4.1.2 Please check whether accessories in the box are complete or not. Please contact the supplier for any shortage, and make sure to keep the accessories in the box intact.**
- 4.1.3 Please choose a proper place for installation of the Camera in advance. Please determine an installation place according to the following requirements:**
 - 4.1.1.1 Confirm the position for the object to be captured.
 - 4.1.1.2 Confirm whether the Camera is set at a proper distance from other light sources.

4.2 Instructions for installation

4.2.1 I would like to install CV620-BK4/WH4 on a desk

4.2.1.1 Precautions for installation

- ◆ Please install the machine on a flat desk
- ◆ Do not grab the camera head by hand when handling the device
- ◆ Do not rotate the camera head by hand. Improper rotation may result in breakdown of the camera

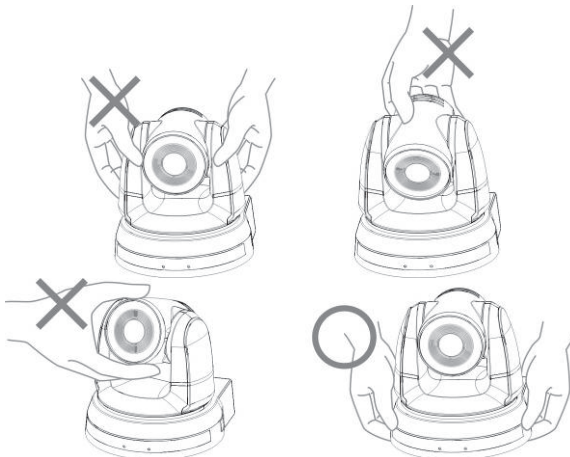

4.2.1.2 Installation steps

1. Please adjust DIP switch at first prior to installation

***Please refer to [Chapter 7 DIP Switch Setting](#) for the relevant descriptions on DIP switch.**

2. Place the camera on a flat desk directly to ensure the normal vertical and horizontal operation of the machine

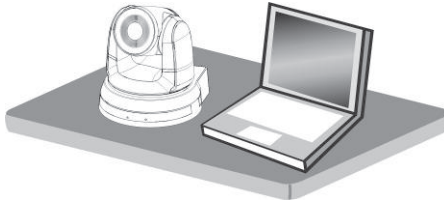

4.2.2 I would like to install CV620-BK4/WH4 on the ceiling

4.2.2.1 Prepare for the parts and equipment required during the installation

1. Accessories of CV620-BK4/WH4 in the box
(metal plates A,B, M3 screw silver x 8, black x 2)
2. Screw for locking on ceiling mounted hanger x 4
3. Drilling machine, screw driver, ladder

4.2.2.2 Camera Size

Length x Width x Height: 174 x 186.2 x 185.5 mm

Weight : 2.0 Kg

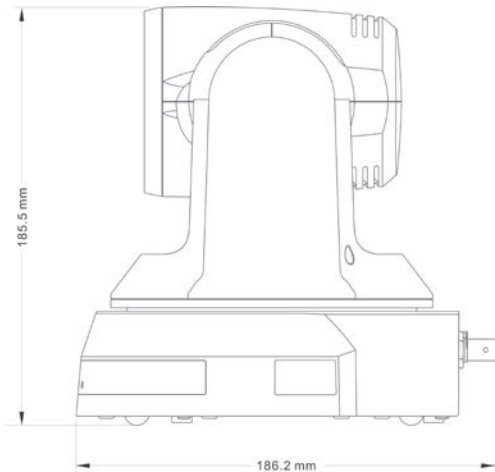
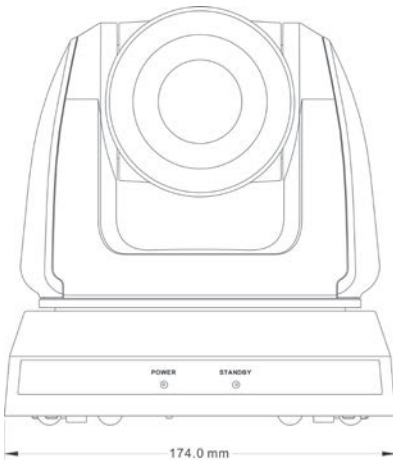

4.2.2.3 Max. rotation dimension of camera

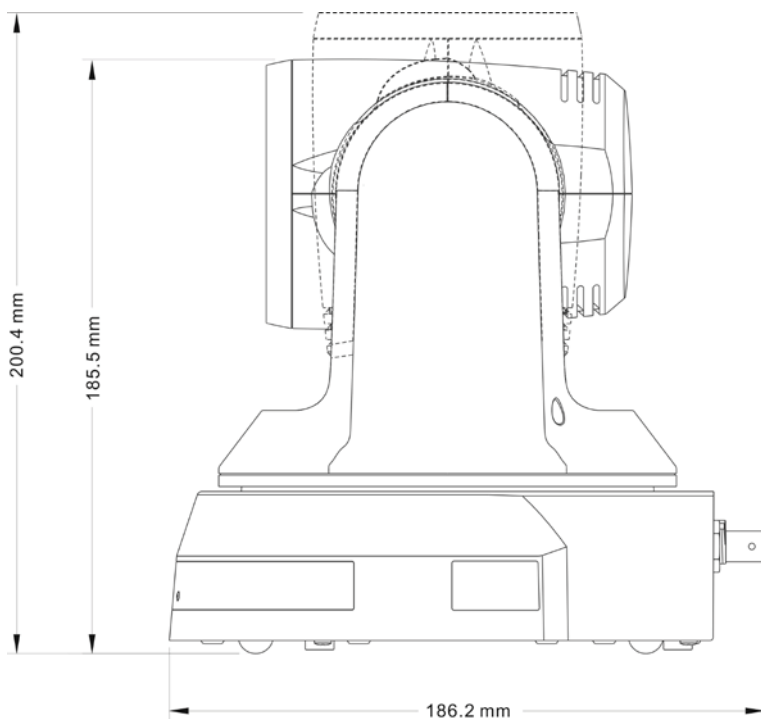

4.2.2.4 Size Diagram

1. Metal plate A - machine side

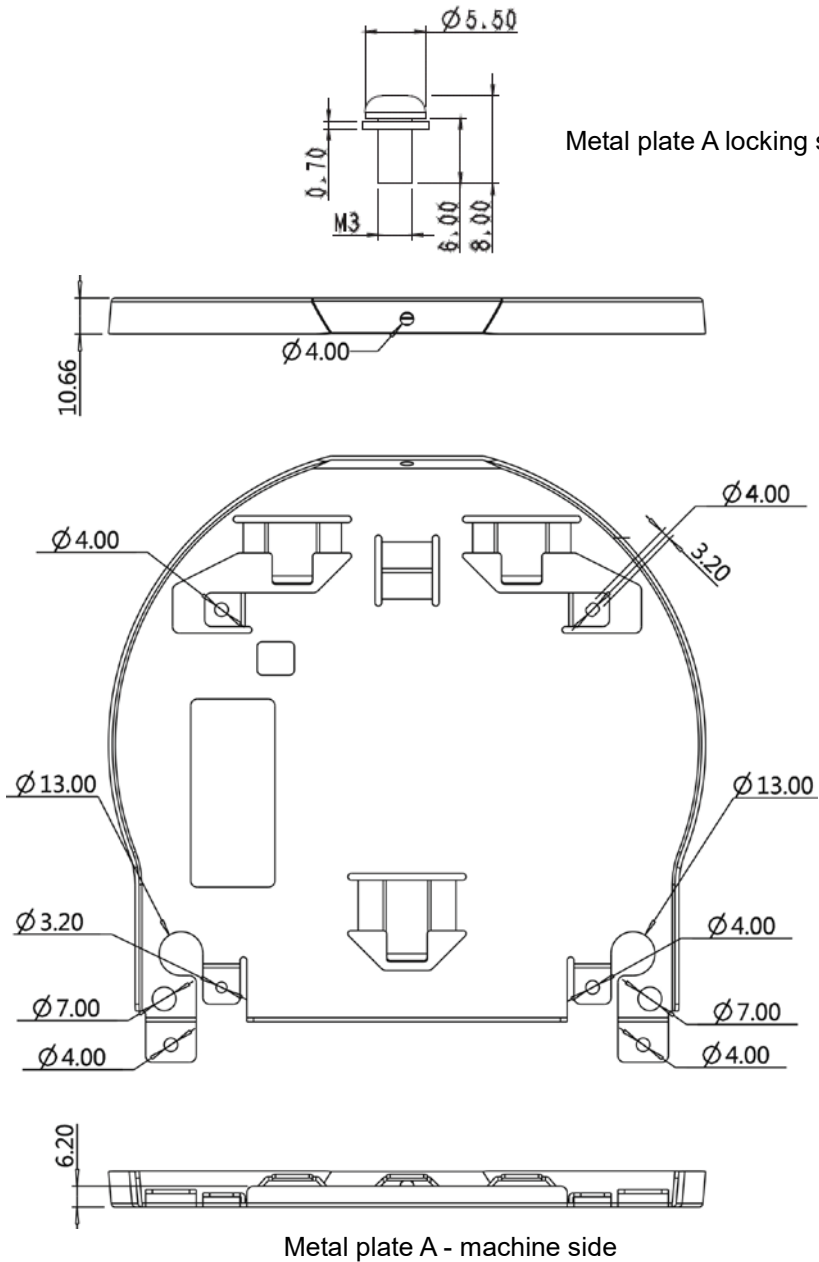

2. Metal plate B - ceiling side

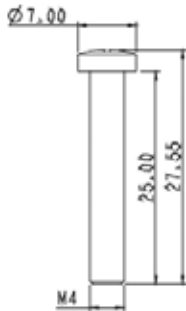

Metal plate B locking screw

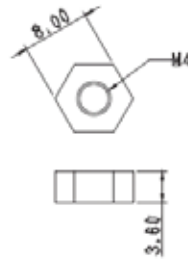

Metal plate B locking bolt

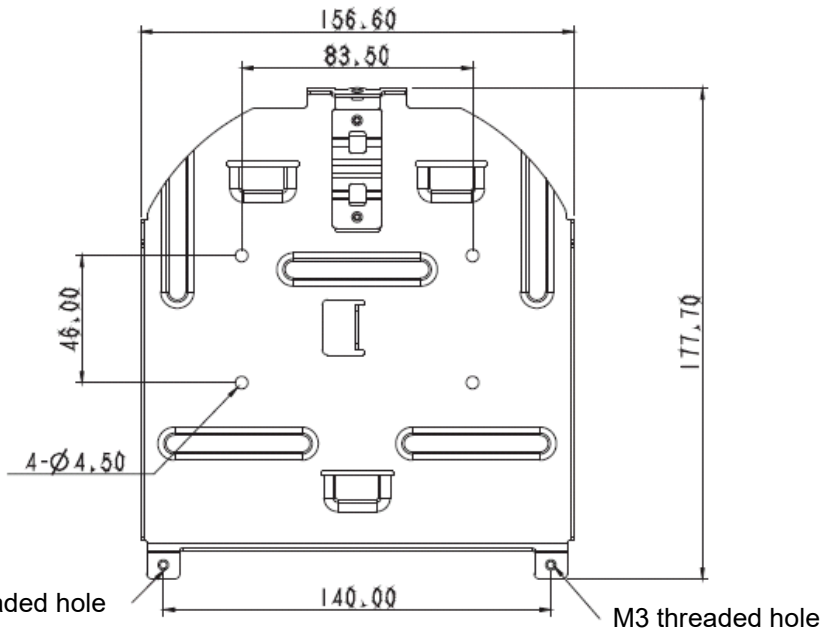

M3 threaded hole

M3 threaded hole

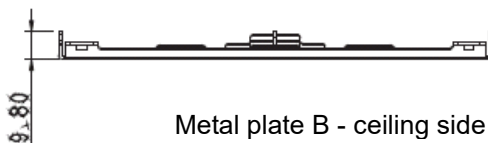

Metal plate B - ceiling side

3. Bottom of camera

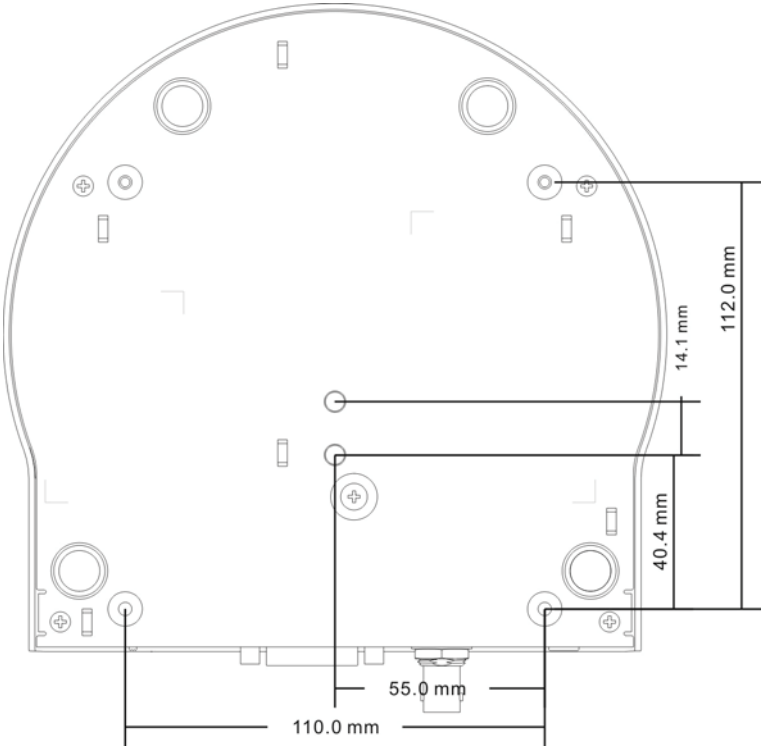

4.2.2.5 Precautions for installation

1. Before installation, please confirm the orientation of the machine relative to the object to be captured.
2. It is recommended that the machine should be set at a distance of more than 1 meter away from the object to be captured. Please adjust for a best distance according to the magnification of the lens.

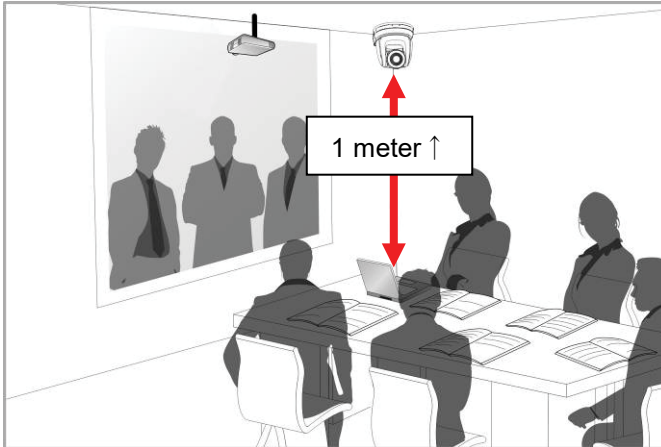

3. The machine (including metal plates) is weighed at about 2.5 kg. If it is to be installed on the ceiling, please use the hanger that has obtained UL security approval to prevent the machine from falling down.
4. Please check whether the camera is installed securely on a regular basis.

4.2.2.6 Installation steps

1. Please adjust resolution on DIP switch at first
***Please refer to [Chapter 7 DIP Switch Setting](#) for the relevant descriptions on DIP switch.**
2. Fix the metal plate A on the machine base with 4 M3 silver screws

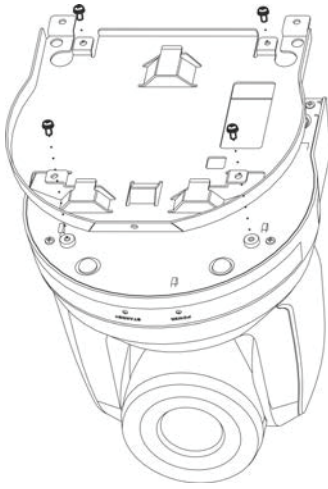

3. Lock the metal plate B on ceiling mounted hanger

※Caution:

- (1) Please use the hanger that has obtained UL security approval
- (2) Please reserve the hole for the connecting wires of the camera

4. Combine the metal plate A and the metal plate B

- (1) Push the metal plate A up to the ceiling and then to the right to latch the metal plate B
- (2) And then secure with 2 M3 silver screws and 1 M3 black screw

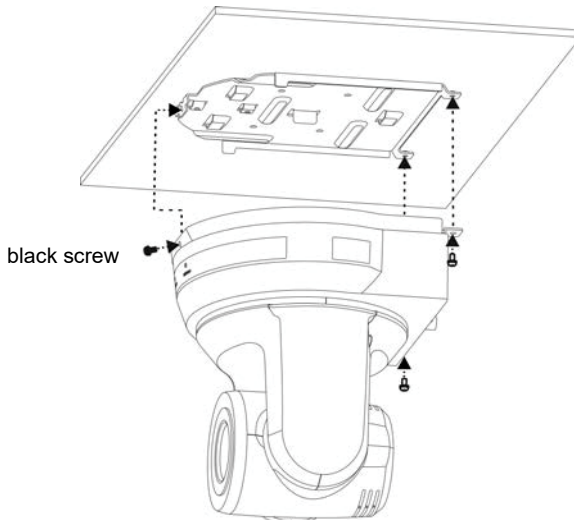

4.2.2.7 How to remove

1. Remove the connecting wires from the camera
2. Uninstall the camera together with the ceiling, loosen the three screws that fix the metal plates A and B and push to the left to remove the machine

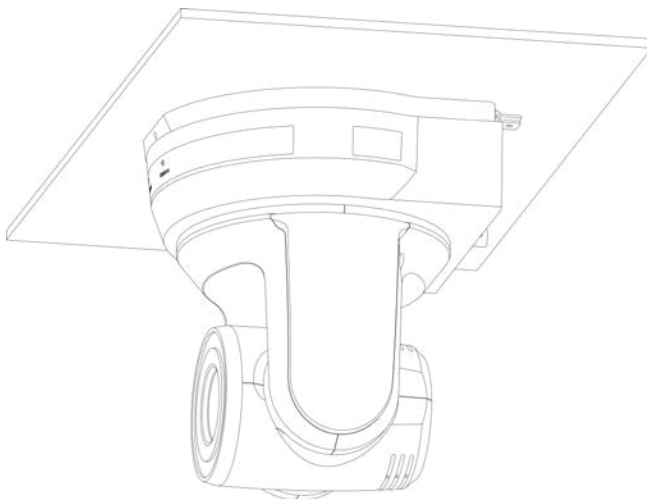

3. Remove the screws on the hanger and the machine

4.3 Connecting the device

4.3.1 Image Output

4.3.1.1 Connecting to a HDTV / computer monitor (DVI)

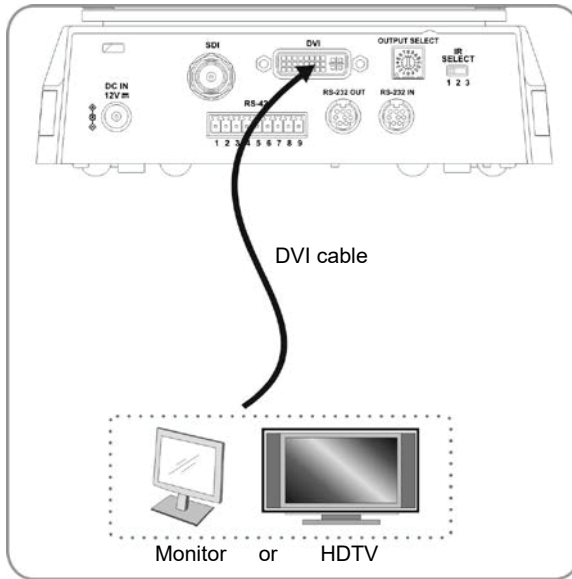

4.3.1.2 Connecting to an HDTV (3G-SDI)

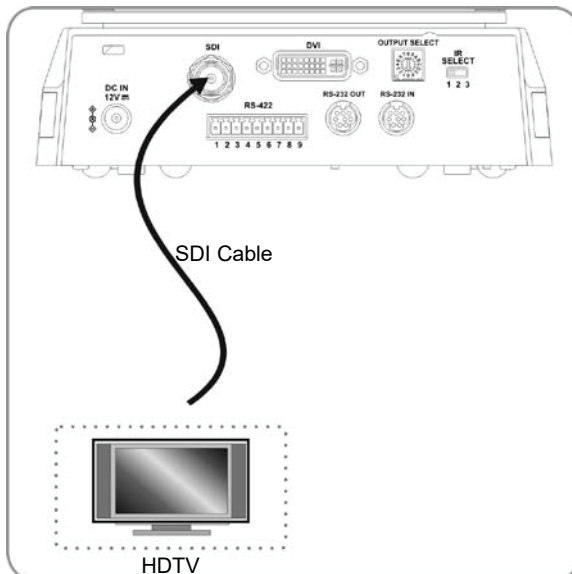

4.3.2 Controlling CV620-BK4/WH4s with the computer

4.3.2.1 Connecting to one computer for connection between CV620-BK4/WH4s (RS-232 in/out)

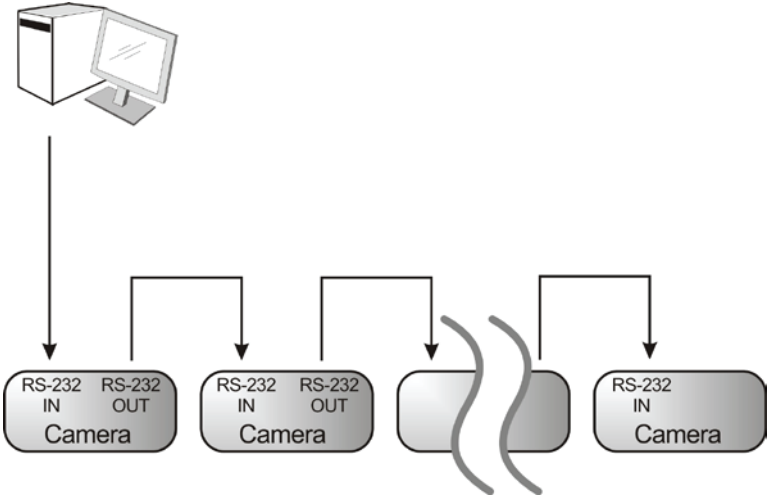

* **With RS-232 in/out, at most 7 CVs can be connected.**

4.3.2.2 Connecting to one computer for connection between CV620-BK4/WH4s (RS-422)

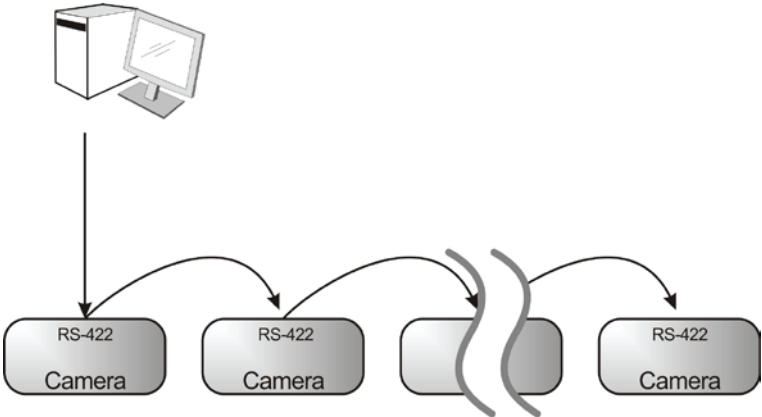

*Please refer to [7.2 RS-422 connection](#) for the RS-422 connection instructions.
*With RS-422, at most 7 CVs can be connected.

Chapter 5 Remote Control and Setting Menu

5.1 Functions of remote control

* The below functions are listed alphabetically.

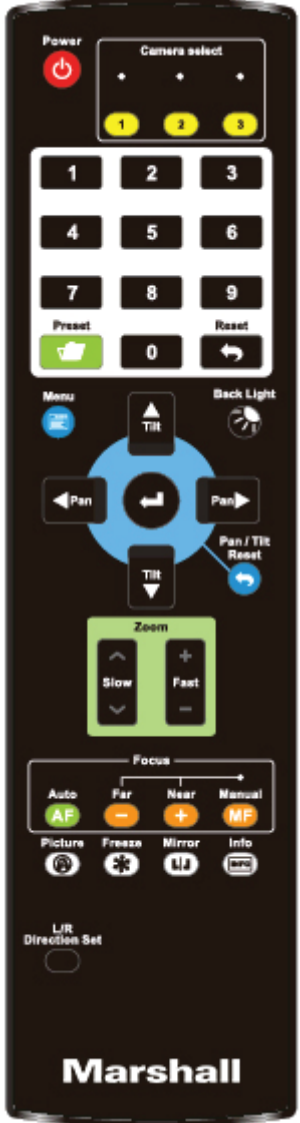
	Item	Description
	◀,▶,▲,▼	Move the lens
	Back Light	Turn on/off back light compensation
	Camera select	Select 1 ~ 3 CV620-BK4/WH4
	Focus-Manual / Far/Near	Turn on manual focus to adjust the focal length
	Focus-Auto	Auto Focus
	Freeze	Freeze the screen
	Home-Enter	Go back to the main page / Execute
	Info	Status information
	L/R Direction Set	L/R Direction / Normal
	Menu	Display OSD menu
	Mirror	Rotate the image (OFF / Mirror / Flip / Rotate)
	Pan/Tilt Reset	Clear the Pan / Tilt setting
	Picture	Switch image effect (OFF / Neg / B&W)
	Power	Power Switch
	Preset	Appoint an ID (0 ~ 9) to save the current position data
	Reset	Appoint an ID (0 ~ 9) to delete the current position data
	Zoom-Fast	Adjust image size
	Zoom-Slow	Fine-tune image size

5.2 Setting Menu

*Press **[Menu]** on the **remote control** to enter the setting menu; the **bold underlined** values in the following table are defaults.

1st Level Major Items	2nd Level Minor Items	3rd Level Adjustment Values		Function Descriptions	
Exposure	Mode	1. <u>Full Auto</u> 2. Shutter Pri 3. Iris Pri 4. Manual 5. White Board		Exposure mode setting	
	Exposure Comp.	On / <u>Off</u>		AE Level	
	Exposure Comp. Level	-6~ <u>C</u> ~4		The value can be adjusted only after Exposure Comp. is activated	
	Spot Light	On / <u>Off</u>		The value can be adjusted when the mode is set to Full Auto or Shutter Pri	
	Spot Light Position	X(0~8)Y(0~6)		The value can be adjusted only after Spot Light is activated	
	Shutter Priority		60/30 mode	50/25 mode	Shutter priority setting
			1/10000	1/10000	
			1/5000	1/5000	
			1/3000	1/3000	
			1/2500	1/2500	
			1/2000	1/1750	
			1/1500	1/1250	
		1/1000	1/1000		
		1/725	1/600		
		1/500	1/425		
		1/350	1/300		
	1/250	1/215			
	1/180	1/150			

		1/120	1/120	
		1/100	1/100	
		1/90	1/75	
		<u>1/60</u>	<u>1/50</u>	
		1/30	1/25	
		1/15	1/12	
		1/8	1/6	
		1/4	1/3	
		1/2	1/2	
		1/1	1/1	
		Iris Priority	1. <u>F1.6</u>	
2. F2				
3. F2.2				
4. F2.7				
5. F3.2				
6. F3.8				
7. F4.5				
8. F5.4				
9. F6.3				
10. F7.8				
11. F9				
12. F11				
13. F13				
14. F16				
15. F18				

	Manual Gain	<ol style="list-style-type: none"> 1. 0dB 2. 2 dB 3. 4 dB 4. 6 dB 5. 8 dB 6. 10 dB 7. 12 dB 8. 14 dB 9. 16 dB 10. 18 dB 11. 20 dB 12. 22 dB 13. 24 dB 14. 26 dB 15. 28 dB 16. 30 dB 		Manually set the gain																																
	Manual Speed	<table border="1" style="width: 100%; border-collapse: collapse;"> <tr> <td style="text-align: center;">60/30 mode</td> <td style="text-align: center;">50/25 mode</td> </tr> <tr><td style="text-align: center;">1/10000</td><td style="text-align: center;">1/10000</td></tr> <tr><td style="text-align: center;">1/5000</td><td style="text-align: center;">1/5000</td></tr> <tr><td style="text-align: center;">1/3000</td><td style="text-align: center;">1/3000</td></tr> <tr><td style="text-align: center;">1/2500</td><td style="text-align: center;">1/2500</td></tr> <tr><td style="text-align: center;">1/2000</td><td style="text-align: center;">1/1750</td></tr> <tr><td style="text-align: center;">1/1500</td><td style="text-align: center;">1/1250</td></tr> <tr><td style="text-align: center;">1/1000</td><td style="text-align: center;">1/1000</td></tr> <tr><td style="text-align: center;">1/725</td><td style="text-align: center;">1/600</td></tr> <tr><td style="text-align: center;">1/500</td><td style="text-align: center;">1/425</td></tr> <tr><td style="text-align: center;">1/350</td><td style="text-align: center;">1/300</td></tr> <tr><td style="text-align: center;">1/250</td><td style="text-align: center;">1/215</td></tr> <tr><td style="text-align: center;">1/180</td><td style="text-align: center;">1/150</td></tr> <tr><td style="text-align: center;">1/120</td><td style="text-align: center;">1/120</td></tr> <tr><td style="text-align: center;">1/100</td><td style="text-align: center;">1/100</td></tr> <tr><td style="text-align: center;">1/90</td><td style="text-align: center;">1/75</td></tr> </table>		60/30 mode	50/25 mode	1/10000	1/10000	1/5000	1/5000	1/3000	1/3000	1/2500	1/2500	1/2000	1/1750	1/1500	1/1250	1/1000	1/1000	1/725	1/600	1/500	1/425	1/350	1/300	1/250	1/215	1/180	1/150	1/120	1/120	1/100	1/100	1/90	1/75	Manually set the shutter
60/30 mode	50/25 mode																																			
1/10000	1/10000																																			
1/5000	1/5000																																			
1/3000	1/3000																																			
1/2500	1/2500																																			
1/2000	1/1750																																			
1/1500	1/1250																																			
1/1000	1/1000																																			
1/725	1/600																																			
1/500	1/425																																			
1/350	1/300																																			
1/250	1/215																																			
1/180	1/150																																			
1/120	1/120																																			
1/100	1/100																																			
1/90	1/75																																			

		<u>1/60</u>	<u>1/50</u>	
		1/30	1/25	
		1/15	1/12	
		1/8	1/6	
		1/4	1/3	
		1/2	1/2	
		1/1	1/1	
	Manual Iris	<ol style="list-style-type: none"> 1. <u>F1.6</u> 2. F2 3. F2.2 4. F2.7 5. F3.2 6. F3.8 7. F4.5 8. F5.4 9. F6.3 10. F7.8 11. F9 12. F11 13. F13 14. F16 15. F18 		Manually set the iris
	Gain Limit	<ol style="list-style-type: none"> 1. 8 dB 2. 10 dB 3. 12 dB 4. 14 dB 5. 16 dB 6. 18 dB 7. 20 dB 8. 22 dB 9. 24 dB 10. 26 dB 11. 28 dB 12. <u>30dB</u> 		The maximum electric gain limit.

	Iris Limit	<ol style="list-style-type: none"> 1. F1.6 2. <u>F2.2</u> 3. F3.2 4. F4.5 5. F6.3 6. F9 7. F13 8. F18 	Max. limit value of iris
	WDR	<ol style="list-style-type: none"> 1. <u>Off</u> 2. 1 3. 2 4. 3 5. 4 6. 5 	Set WDR
	Anti Flicker	<ol style="list-style-type: none"> 1. 50Hz 2. 60Hz 1. <u>Off</u> 	Set the image sync frequency during capturing
White Balance	Mode	<ol style="list-style-type: none"> 1. <u>Auto</u> 2. Indoor 3. Outdoor 4. One Push WB 5. ATW 6. Sodium Lamp 7. Manual 8. 3000K 9. 4300K 10. 5000K 11. 6500K 12. 8300K 13. WideAuto 	Select the color temperature mode <ol style="list-style-type: none"> 1. 4000k ~ 7000k 2. 3200k 3. 5800k 4. 1700k ~ 10000k 5. 1700k ~ 10000k 6. 2800k 7. Custom 8. 3000K 9. 4300K 10. 5000K 11. 6500K 12. 8000K 13. 3000k ~ 7000k
	One Push Trigger	<u>ENTER</u>	One push trigger
	Manual Red	0~ <u>C</u> ~60	Adjustable when the white balance mode is set to Manual

	Manual Blue	0~ <u>C</u> ~60	Adjustable when the white balance mode is set to Manual
Picture	Picture effect	1. <u>Off</u> 2. Neg 3. B & W	Set the picture effect
	Sharpness	1~ <u>A</u> ~16	Adjust the sharpness of the image
	2D NR	1. <u>Auto</u> 2. Off 3. 1 4. 2 5. 3 6. 4 7. 5	Set 2D noise reduction
	3D NR	1. Off 2. <u>LOW</u> 3. Typ 4. Max 5. Auto	Set 3D dynamic noise reduction
	Image Mode	1. Mode1 2. Mode2 3. Mode3 4. Mode4 5. <u>Mode5</u> 6. Mode6 7. Custom	The user may customize his/her desired image mode
	Image Mode Load	1. <u>Mode1</u> 2. Mode2 3. Mode3 4. Mode4 5. Mode5 6. Mode6	Adjustable when the Image mode is set to Custom . After selected, the corresponding Image mode parameters will be read and applied to Custom
	Saturation	0~ <u>A</u> ~25	Adjustable when the Image mode is set to Custom mode
	Hue	0~ <u>A</u> ~14	Adjustable when the Image mode is set to Custom mode

	Gamma	0~ <u>A</u> ~3	Adjustable when the Image mode is set to Custom mode
	Skin Tone	1~ <u>A</u> ~5	Skin tone settings; adjustable when Image mode is set to Custom mode
	Brightness	0~ <u>A</u> ~14	Adjustable when the Image mode is set to Custom
	Contrast	0~ <u>A</u> ~14	Contrast adjustment; Adjustable when the Image mode is set to Custom
	Black Level	1. <u>Off</u> 2. Type 1 3. Type 2 4. Type 3	Adjust the shadow details and transparency of the screen, adjustable when the Image mode is set to Custom
Pan Tilt Zoom	Pan/Tilt Limit	On / <u>Off</u>	Turn on/off the angle limit setting
	Pan Right Limit	0~ <u>170</u>	Limit the right angle
	Pan Left Limit	<u>-170</u> ~0	Limit the left angle
	Tilt UP Limit	0~ <u>90</u>	Limit the upward angle
	Tilt Down Limit	<u>-30</u> ~0	Limit the downward angle
	Pan Flip	On / <u>Off</u>	When turned on, Pan command will be reversed
	Tilt Flip	On / <u>Off</u>	When turned on, Tilt command will be reversed
	Pan/Tilt Speed	<u>Normal</u> /Smooth	Adjust Pan/Tilt Speed
	Preset Speed	1. 5 deg/sec 2. 25 deg/sec 3. 50 deg/sec 4. 80 deg/sec 5. 120 deg/sec 6. <u>160 deg/sec</u> 7. 200 deg/sec 8. 300 deg/sec	Set the rotation speed of the cradle head when Preset is executed

	PTZ Speed Comp	<u>On</u> / Off	Set the Pan/Tilt Moving speed subject to the zoom position
	D-Zoom Limit	<u>x1</u> ~x12	Limit the D-zoom multiple
D-Effect	Mirror	1. <u>Off</u> 2. Mirror 3. Flip 4. Mirror + Flip	Set the mode at which the image is turned
Auto Focus	AF Sensitivity	1. LOW 2. <u>Middle</u> 3. High	Select the AF triggering speed. The higher the speed is, the faster AF is triggered
	AF Frame	<u>Full Frame</u> / Center	AF frame setting, when central area was set as AF frame, focusing will be on the center of the screen. When Full Frame was set as AF frame, focusing will be calculated based on the full screen
System	Video Type	SDI	Select video output type
		<u>DVI-I</u>	
	Prompt	On / <u>Off</u>	Turn on/off the prompt information on the display
	IR Receive	<u>On</u> / Off	Turn on/off the infrared reception
	Language	<u>English</u> / Chinese	Language
	Control Device	Encoder / <u>Controller</u>	Control Device setting, Controller : for joystick Encoder : for tracking system
	Motionless Preset	On / <u>Off</u>	When the function is enabled, the screen will Freeze when Preset is executed. Freeze will be released after Preset is completed.
Protocol	<u>Protocol V</u> / Protocol PD	Protocol V: VISCA Protocol PD: PELCO D	

	PD Address	1~ <u>C</u> ~255	The Protocol set to PD allows the camera ID address to be assigned
	Camera Address	<u>0</u> ~7	
	Output Mode	<ol style="list-style-type: none"> 1. <u>1920x1080/60p</u> 2. 1920x1080/50p 3. 1920x1080/30p 4. 1920x1080/25p 5. 1920x1080/60i 6. 1920x1080/50i 7. 1280x720/60p 8. 1280x720/50p 9. 1280x720/30p 10. 1280x720/25p 11. 1080/59.94p 12. 1080/59.94i 13. 1080/29.97p 14. 720/59.94p 15. 720/29.97p 	Choose the output resolution
	Control Protocol	<u>RS-232C</u> /RS-422	Choose whether the control interface used is RS-232C or RS-422
	Baud Rate	<u>9600</u> /38400	Choose the transmission speed of the control signal
	Factory Reset	On / <u>Off</u>	Resume the factory default setting
Status			Display the current setting status

Chapter 6 Descriptions of Major Functions

6.1 I would like to switch to CV620-BK4/WH4

1. Press [**Camera 1 ~ 3**] on the **remote control** to select CV620-BK4/WH4.
 - **Camera 1 ~ 3** is selected with **IR SELECT**.

6.2 I would like to save the current lens position data

1. Hold [**Preset + ID**] on the **remote control** to save the current position data.
 - **ID** shall be a digit [0 ~ 9].
 - Use **VISCA Command** to save the position data to [0 ~ 127].

6.3 I would like to clear the saved position data

1. Hold [**Reset + ID**] on the **remote control** to clear the given position data.
 - **ID** shall be a digit [0 ~ 9].
 - Use **VISCA Command** to clear the position data stored of [0 ~ 127].

6.4 I would like to turn on the back light compensation function

1. Press [**Back Light**] on the **remote control** to turn on or turn off the back light compensation

6.5 I would like to adjust the shooting angle of the lens

1. Press [**Tilt ▲**] or [**Tilt ▼**] on the **remote control** to adjust the angle upward or downward.
2. Press [**Pan ►**] or [**Pan ◄**] on the **remote control** to adjust the angle to the right or left.
3. Press [**Pan - Tilt Reset**] on the **remote control** to reset the angle to the center point.

6.6 I would like to hide the preset image switch (Motionless Preset)

1. Press [**MENU**] to activate the setting menu.

2. Press [**▶**] or [**◀**] to select [**System**].
3. Press [**ENTER**] to activate.
4. Press [**▲**] or [**▼**] to select [**Motionless Preset**].
5. Press [**ENTER**] to activate.
6. Press [**▶**] or [**◀**] to select [**Off / On**].
7. Press [**MENU**] to exit.

6.7 I would like to zoom in/out images

6.7.1 Adjust image size

1. Press [**Fast +**] on the **remote control** to zoom in images.
2. Press [**Fast -**] on the **remote control** to zoom out images.

6.7.2 Fine-tune image size

1. Press [**Slow +**] on the **remote control** to zoom in images.
2. Press [**Slow -**] on the **remote control** to zoom out images.

6.8 I would like to adjust the focal length

6.8.1 Auto tune

1. Press [**AF**] on the **remote control** to adjust automatically.

6.8.2 Manual focus

1. Press [**MF**] on the **remote control** to turn on the manual focus function.
2. Press **Focus - [+]** or **Focus - [-]** to adjust.

6.9 I would like to adjust the AF sensitivity

Triggering speed of focus. The higher the speed is, the faster focus is triggered.

To shoot fast-moving objects, **AF Sensitivity** can be set to [**High**] or [**Medium**], which is applicable to quick focus.

When the environment is too dark to enable auto focus or fixed objects have to be shot in different brightness, **AF Sensitivity** can be set to [**Low**].

1. Press [**MENU**] to activate the setting menu.
2. Press [**▶**] or [**◀**] to select [Auto Focus].
3. Press [**ENTER**] to activate.
4. Press [**▲**] or [**▼**] to select [AF Sensitivity].
5. Press [**ENTER**] to activate.

6. Press [▶] or [◀] to select [High / Middle / Low].
7. Press [MENU] to exit.

6.10 I would like to set the image mode

1. Press [Picture] on the **remote control** to switch [Off / Neg / B&W].

6.11 I would like to freeze images

1. Press [Freeze] on the **remote control** to freeze the current image on the display.

6.12 I would like to rotate the image

1. Press [Mirror] on the **remote control** to switch [Off / Mirror / Flip / Mirror + Flip].

6.13 I would like to change the camera direction

1. Press [L/R Direction Set] on the **remote control** to switch [L/R Direction / Off / Normal].

6.14 I would like to display the current status

1. Press [Info] on the **remote control** to display the current status information.

6.15 I would like to reset to the original setting

1. Press [MENU] to activate the setting menu.
2. Press [▶] or [◀] to select [System].
3. Press [ENTER] to activate.
4. Press [▲] or [▼] to select [Factory Reset].
5. Press [ENTER] to activate.
6. Press [▶] or [◀] to select [On].
7. Press [ENTER] to execute.

Chapter 7 DIP switch setting

* Please turn off the machine before changing DIP switch setting.

7.1 DIP Switch

7.1.1 OUTPUT Switch



Setting	Function Descriptions
0	1920x1080/60p
1	1920x1080/50p
2	1920x1080/30p
3	1920x1080/25p
4	1920x1080/60i
5	1920x1080/50i
6	1280x720/60p
7	1280x720/50p
8	1280x720/30p
9	1280x720/25p
A	1080/59.94p
B	1080/59.94i
C	1080/29.97p
D	720/59.94p
E	720/29.97p
F	Reserved

7.1.2 IR SELECT

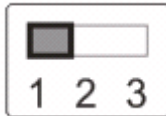

ID	Setting
1	
2	
3	

7.2 RS-422 Connection

7.2.1 RS-422 Pin Description

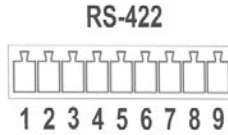

Pin NO.	Function
1	RXD OUT -
2	RXD OUT +
3	TXD OUT -
4	TXD OUT +
5	GND
6	RXD IN -
7	RXD IN +
8	TXD IN -
9	TXD IN +

*For SONY products, please connect IN+ to OUT+

For non-SONY products, it may be necessary to connect IN+ to OUT-

7.2.2 Use RS-422 Connection

1. Hold the two sides of RS-422 connector and pull out in the direction shown by the arrow in the figure below

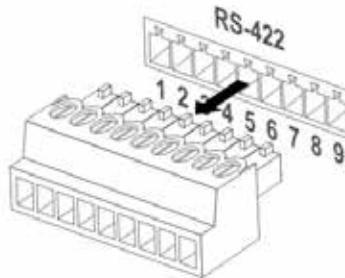

2. Peel off a section of copper wire (AWG Nos. 28 to 18) and insert it into the connector hole; then use a flat head screw driver to fix it

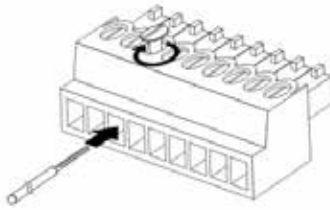

3. Insert the wired RS-422 connector back to the camera. Now the connection is completed

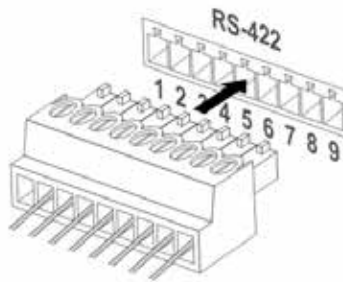

- * When RS-422 connection is being used, do not use RS-232C connection.

Chapter 8 Troubleshooting

This chapter describes problems you may encounter while using the CV620-BK4/WH4. If you have questions, please refer to related chapters and follow all suggested solutions. If the problem still occurs, please contact your distributor or service center.

No.	Problems	Solutions
1.	Boot without power signal	Make sure you have plugged in the power cord.
2.	There is no image output from CV620-BK4/WH4	<ol style="list-style-type: none">1. Check the power.2. Check if DIP switch is properly set. Refer to Chapter 7 DIP switch setting for related settings.3. Make sure the display supports the output resolution; in general, the resolution is 1080p60/1080i60/720p60.4. Replace the cables and make sure they are not faulty.
3.	CV620-BK4/WH4 image is severely delayed	Please use 1080p or 720p 60/50 Hz signals rather than 25/30 Hz signals.
4.	Not working after changes to DIP Switch setting	After completing DIP Switch setting, unplug and reconnect the power cord and turn on the machine to change the setting.
5.	CV620-BK4/WH4 cannot be operated by remote control	<ol style="list-style-type: none">1. Please confirm if the Camera Select on the remote control can be used together with the IR Select on the Camera.2. Please prevent Camera from direct sunshine.3. Make sure the energy-saving bulb and the IR touch

		<p>screen are as far away from each other? as possible in order to avoid interference.</p> <p>4. When several CV620-BK4/WH4s are connected in the same area, the operation of two remote controls at the same time may result in signal interference. It is recommended to use only one remote control.</p>
6.	The device cannot be controlled with Codec	<p>1. Please consult the distributor to make sure the firmware version is the latest one. The steps to check version is as follows:</p> <ol style="list-style-type: none"> 1.1 Press [MENU] on the remote control 1.2 Choose [Status] 1.3 Go to Page 5 of [System] 1.4 Make sure the firmware version is correct. <p>2. Make sure the connection is correct (RS-232/422 Input).</p> <p>3. Please confirm OSD menu [System]/[Control Protocol] setting.</p>
7.	The device cannot be controlled with RS-232/RS-422	<p>1. Make sure the connection is correct (RS-232/422 Input).</p> <p>2. Please confirm OSD menu [System]/[Control Protocol] setting.</p>