

# DvRigPro. / DvRigPro.HD

## Temporary User Manual

**DvRigPro.**

**DvRigPro.HD**

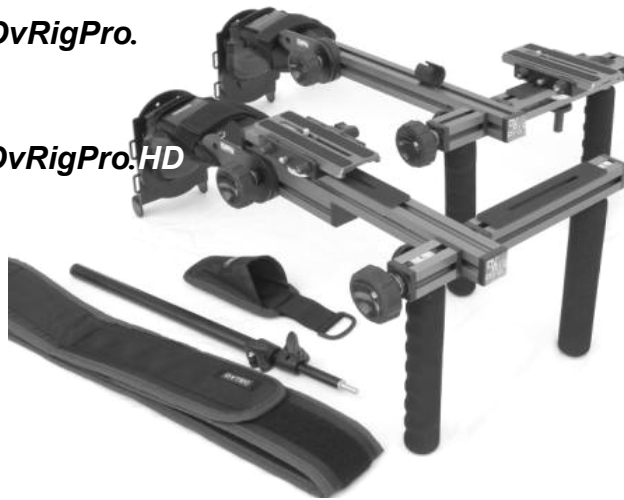

Thank you for choosing the DvRigPro.

The Support pod receptacle (1) and the camera mount (2) can be moved left and right to best balance various cameras and loads.

Turn the thumbscrews clockwise, adjust position and lock back.

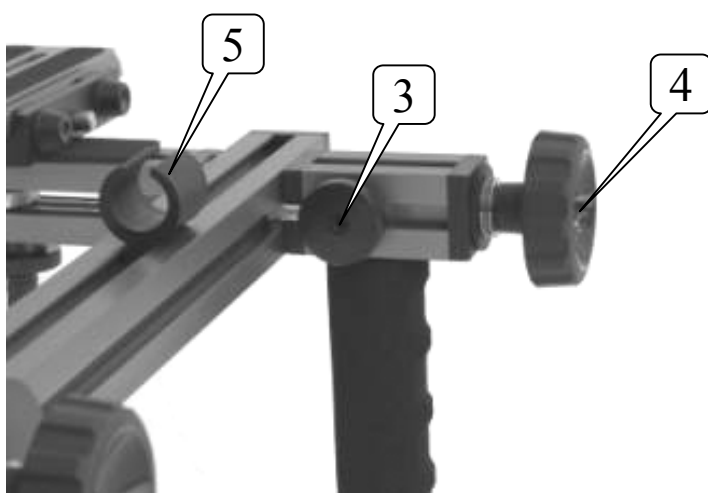
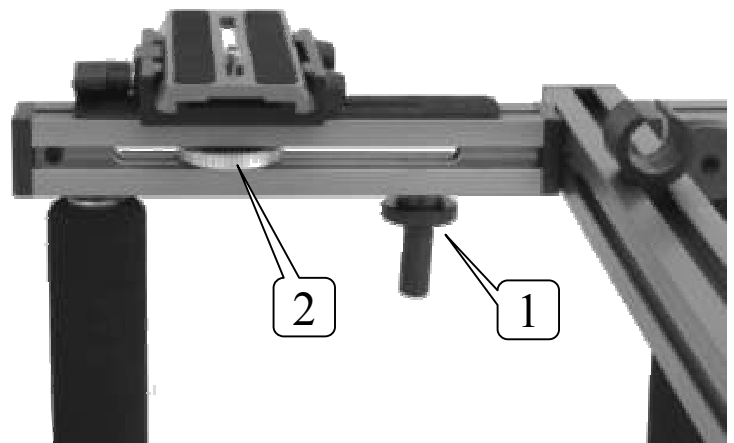

Thumb wheel (3) is controlling the right grip lock. For folding, release and move to the right to unlock the pin. Lock the pin when tilting or for resting the rig on the ground.

Locking Knob (4) is controlling the grips. For free tilting, Lock pin (3) and slightly release the knob. Use the left grip to tilt the camera, keep the right grip locked.

The Flexible pod holder (5) is for storing the support pod when not in use.

To adjust the grips distance, release the main knob (4) and move the front assembly to your best comfort.

Support pod

***The support pod is spring loaded,  
use caution when releasing the locks !!***

Release the pod locks **ONLY AFTER** you place the bottom end in the holster and insert the top end into the rigs spring receptacle.

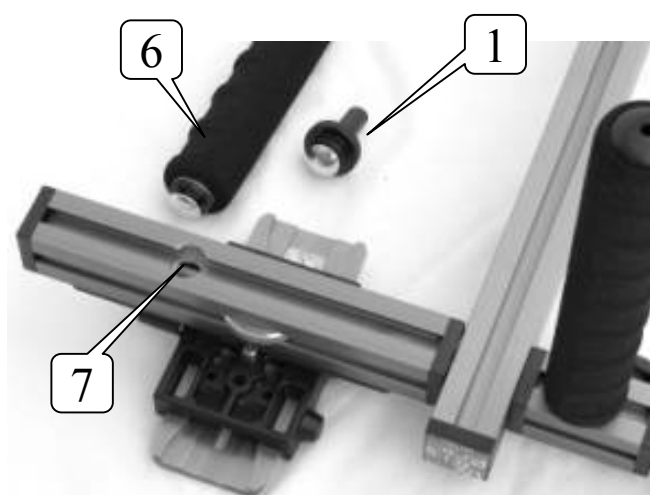

The Support pod tip receptacle (1) and the left grip (6) can be removed from the rail. Turn the grip clockwise, move to hole (7) and pull out.



Standard Broadcast batteries mounts can be mounted on the back acc. plate and used to power the camera, camera lights, HD recorders and other acc.

The acc. plate and the provided Velcro straps can be used to hold WL receivers, HD recorders, sound mixers Etc.

### DvRigPro.HD Only !!

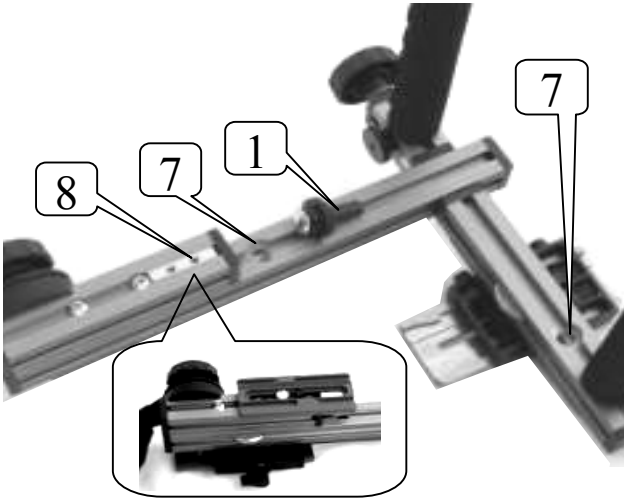

When using the side mount (HD Only) move the Support pod tip receptacle (1) from the front to the side bar by using the release holes (7).

Screw your camera/tripod plate to the threaded holes (8) and mount the whole rig on your Quick Release tripod head.

To move the camera QR Base from the side to the front bar, Place the locking screw opposite The release hole (7).

Unscrew the base plate, push the screw through the hole (7) and slide out the thumb wheel and the black nylon washers.

Insert the thumb wheel with the nylon washer on top into the slot in the other bar opposite the other release hole (7),

Insert the screw back into the assembly, place the QR base on the screw and screw in all the way.

Use the 1/4" threaded inserts to mount your monitor arm Camera light, external mic. Etc.

