

# datavideo

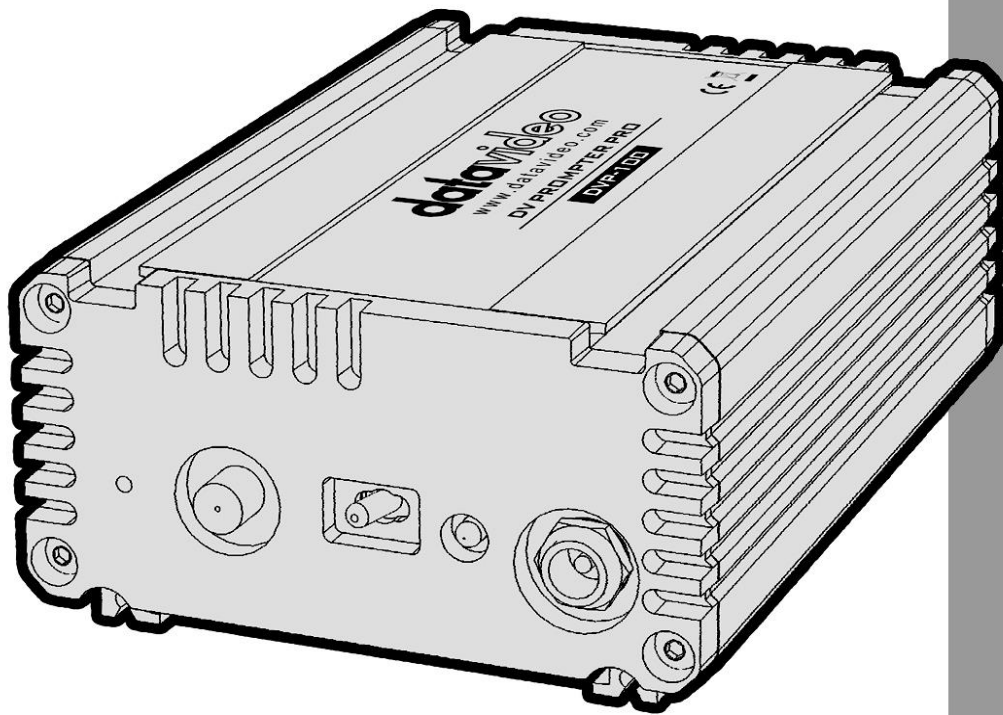

**DV PROMPTER PRO  
PROMPTING SYSTEM  
DVP-100  
Quick Start Guide**

[www.datavideo.com](http://www.datavideo.com)

# Contents

<b>Warnings and Precautions</b> .....	<b>3</b>
Disposal.....	3
Warranty.....	4
Packing List.....	4
<b>Introduction</b> .....	<b>5</b>
Features .....	5
Example set up.....	6
<b>Connections &amp; Controls</b> .....	<b>7</b>
Front Panel.....	7
<b>Connecting to DVP-100 with an iOS tablet</b> .....	<b>8</b>
<b>Connecting to DVP-100 with a laptop (Web browser)</b> .....	<b>9</b>
<b>Using DVP-100</b> .....	<b>10</b>
<b>Home Page</b> .....	<b>10</b>
<b>Controller Page</b> .....	<b>11</b>
<b>Prompter Page</b> .....	<b>12</b>
<b>Script Editor Page</b> .....	<b>13</b>
Creating & Importing Scripts.....	13
Editing Scripts .....	13
<b>Loading Scripts</b> .....	<b>14</b>
<b>Playlist</b> .....	<b>15</b>
<b>Network Administration / Software Updates</b> .....	<b>16</b>
Finding the DVP-100 device IP address.....	16
<b>Connecting to the DVP-100 administration interface</b> .....	<b>17</b>
<b>Changing Wi-Fi settings</b> .....	<b>18</b>
<b>System updates</b> .....	<b>19</b>
<b>Factory Reset</b> .....	<b>19</b>
<b>Frequently-Asked Questions</b> .....	<b>19</b>
<b>Specifications</b> .....	<b>20</b>
<b>Service &amp; Support</b> .....	Error! Bookmark not defined.

## Disclaimer of Product and Services

The information offered in this instruction manual is intended as a guide only. At all times, Datavideo Technologies will try to give correct, complete and suitable information. However, Datavideo Technologies cannot exclude that some information in this manual, from time to time, may not be correct or may be incomplete. This manual may contain typing errors, omissions or incorrect information. Datavideo Technologies always recommend that you double check the information in this document for accuracy before making any purchase decision or using the product. Datavideo Technologies is not responsible for any omissions or errors, or for any subsequent loss or damage caused by using the information contained within this manual. Further advice on the content of this manual or on the product can be obtained by contacting your local Datavideo Office or dealer.

## Warnings and Precautions



1. Read all of these warnings and save them for later reference.
2. Follow all warnings and instructions marked on this unit.
3. Unplug this unit from the wall outlet before cleaning. Do not use liquid or aerosol cleaners. Use a damp cloth for cleaning.
4. Do not use this unit in or near water.
5. Do not place this unit on an unstable cart, stand, or table. The unit may fall, causing serious damage.
6. Slots and openings on the cabinet top, back, and bottom are provided for ventilation. To ensure safe and reliable operation of this unit, and to protect it from overheating, do not block or cover these openings. Do not place this unit on a bed, sofa, rug, or similar surface, as the ventilation openings on the bottom of the cabinet will be blocked. This unit should never be placed near or over a heat register or radiator. This unit should not be placed in a built-in installation unless proper ventilation is provided.
7. This product should only be operated from the type of power source indicated on the marking label of the AC adapter. If you are not sure of the type of power available, consult your Datavideo dealer or your local power company.
8. Do not allow anything to rest on the power cord. Do not locate this unit where the power cord will be walked on, rolled over, or otherwise stressed.
9. If an extension cord must be used with this unit, make sure that the total of the ampere ratings on the products plugged into the extension cord do not exceed the extension cord's rating.
10. Make sure that the total amperes of all the units that are plugged into a single wall outlet do not exceed 15 amperes.
11. Never push objects of any kind into this unit through the cabinet ventilation slots, as they may touch dangerous voltage points or short out parts that could result in risk of fire or electric shock. Never spill liquid of any kind onto or into this unit.
12. Except as specifically explained elsewhere in this manual, do not attempt to service this product yourself. Opening or removing covers that are marked "Do Not Remove" may expose you to dangerous voltage points or other risks, and will void your warranty. Refer all service issues to qualified service personnel.
13. Unplug this product from the wall outlet and refer to qualified service personnel under the following conditions:
  - a. When the power cord is damaged or frayed;
  - b. When liquid has spilled into the unit;
  - c. When the product has been exposed to rain or water;
  - d. When the product does not operate normally under normal operating conditions. Adjust only those controls that are covered by the operating instructions in this manual; improper adjustment of other controls may result in damage to the unit and may often require extensive work by a qualified technician to restore the unit to normal operation;
  - e. When the product has been dropped or the cabinet has been damaged;
  - f. When the product exhibits a distinct change in performance, indicating a need for service.

## Disposal



### For EU Customers only - WEEE Marking

This symbol on the product indicates that it should not be treated as household waste. It must be handed over to the applicable take-back scheme for the recycling of Waste Electrical and Electronic Equipment. For more detailed information about the recycling of this product, please contact your local Datavideo office.

## Warranty

### Standard Warranty

- Datavideo equipment is guaranteed against any manufacturing defects for one year from the date of purchase.
- The original purchase invoice or other documentary evidence should be supplied at the time of any request for repair under warranty.
- Damage caused by accident, misuse, unauthorized repairs, sand, grit or water is not covered by this warranty.
- All mail or transportation costs including insurance are at the expense of the owner.
- All other claims of any nature are not covered.
- Cables & batteries are not covered under warranty.
- Warranty only valid within the country or region of purchase.
- Your statutory rights are not affected.

### Two Year Warranty

All Datavideo products purchased after 01-Oct.-2008 qualify for a free one year extension to the standard Warranty, providing the product is registered with Datavideo within 30 days of purchase. For information on how to register please visit [www.datavideo.com](http://www.datavideo.com) or contact your local Datavideo office or authorized Distributors

Certain parts with limited lifetime expectancy such as LCD Panels, DVD Drives and Hard Drives are only covered for the first 10,000 hours, or 1 year (whichever comes first).

Any second year warranty claims must be made to your local Datavideo office or one of its authorized Distributors before the extended warranty expires.

### Packing List

Items	Description	Q'ty
1	DVP-100 Unit	1
2	Instruction Manual	1
3	Accessory List	1

## Introduction

The DVP-100 wireless prompting system is a teleprompting system that is compatible with Apple, Windows, Android, and iOS devices.

The DVP-100 creates its own dedicated Wi-Fi hotspot allowing the production team to connect up to six devices for prompting purposes. Once connected to the DVP-100, each device can be set to be either be a controller, an editor or a prompting screen.

A controller device allows the user to load new scripts, control the current prompting session or perform a live edit, in real time, on the prompting screens.

All scripts are stored centrally on the DVP-100 and not on the prompting devices. This also allows playlists to be created where the running order can be changed or added to on the fly.

As well as using normal copy and paste functions, scripts can be imported from .txt or html files allowing existing content to be repurposed quickly and easily.

## Features

- Script playback kept in sync across multiple control / prompting devices
- Embedded rich text editor – adjust font, size and colour of text
- Perform live text edits on the fly during prompting
- Remote control and script management over a dedicated Wi-Fi spot
- Multiple prompting devices controlled from one computer or manual remote
- Multi user collaboration over IP to create a script library within the DVP-100
- Script library used to create and manage script playlists
- Built in dual band Wi-Fi allows easy control and management
- Control/edit/prompt with any device that has a HTML5 compliant web browser
- Compatible with WR-450 Bluetooth controller to facilitate talent script control
- Independent mirroring of all screens
- Single click or tap on the prompting device to toggle normal/mirrored view
- Double click or double tap to return to control, edit or prompt choices
- Robust small form factor case, 19" rack mountable using optional RMK-2
- Initial standalone Wi-Fi range up to 300ft / 100m – can be extended
- 12V DC input

# Example set up

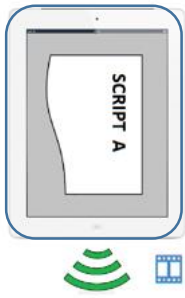

Synchronised Playback\* across multiple devices\*

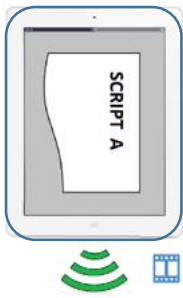

Select a single script or create a playlist

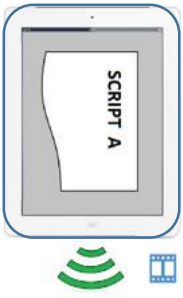

Edit the script live as events change during production







Traditional prompting or talent controlled

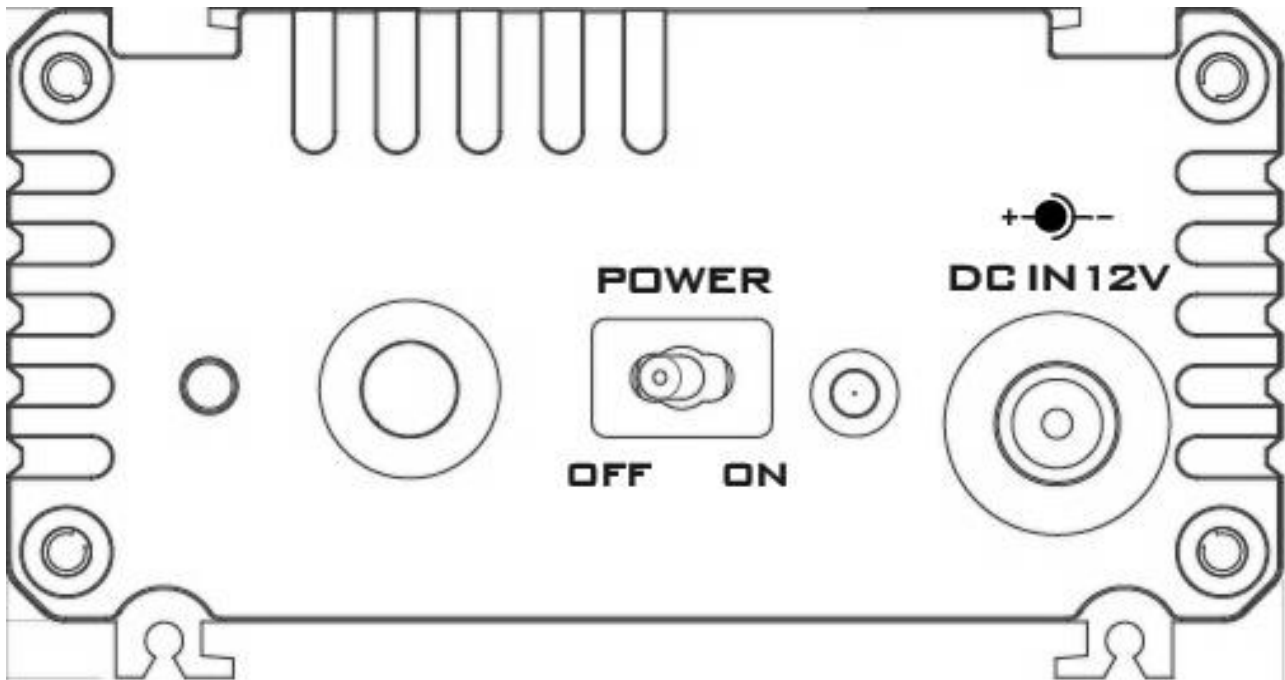

## Connections & Controls

### Front Panel



 <p>POWER OFF ON</p>	<b>Power Switch</b> Switches the power ON/OFF
 <p>DC IN 12V</p>	<b>DC IN Socket</b> Connects the supplied 12V PSU to this socket. The connection can be secured by screwing the outer fastening ring of the DC In plug to the socket.
	<b>Antenna Port</b> Connects to the supplied dual band Wi-Fi antenna
	<b>Reset</b> Resets the device to factory defaults

## Connecting to DVP-100 with an iOS tablet

1. Download the app called **DVP-100** from the Apple app store to the iOS tablet using your normal Wi-Fi network connection.
2. The DVP-100 unit when powered on will create its own **Wi-Fi hotspot called 'dvPrompter'**.
3. In general settings on the iOS tablet connect to the **'dvPrompter'** Wi-Fi network and enter the **password "prompter123"** when prompted.
4. Once connected to the DVP-100 Wi-Fi network, we need to connect to the **dvPrompter Pro** application using the DVP-100 app.
5. **Open the DVP-100 app**, you will see the screen below

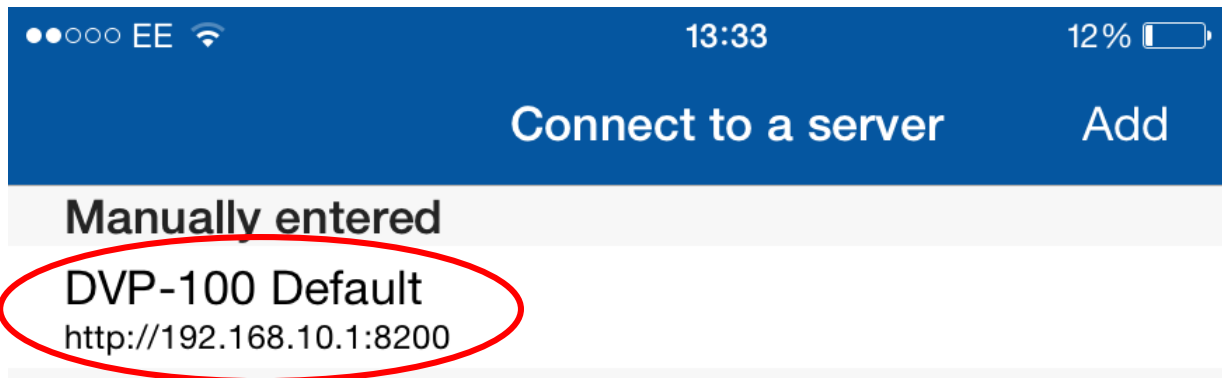

6. Tap the **'DVP-100 Default'** entry at the top of the list.
7. The **home page for DV Prompter Pro** will be displayed.



8. Now turn to page 10 to learn how to set the tablet as either a Controller, Editor or Display device.



## Connecting to DVP-100 with a laptop (Web browser)

1. The DVP-100 unit when powered on will create its own **Wi-Fi hotspot called 'dvPrompter'**.
2. Connect to the '**dvPrompter**' Wi-Fi network and enter the **password "prompter123"** when prompted.
3. Once connected to the DVP-100 Wi-Fi network, we need to connect to the dvPrompter Pro server application within the DVP-100 unit.
4. Open your laptop web browser, Chrome or Firefox is recommended, and enter <http://192.168.10.1:8200> into the address bar.

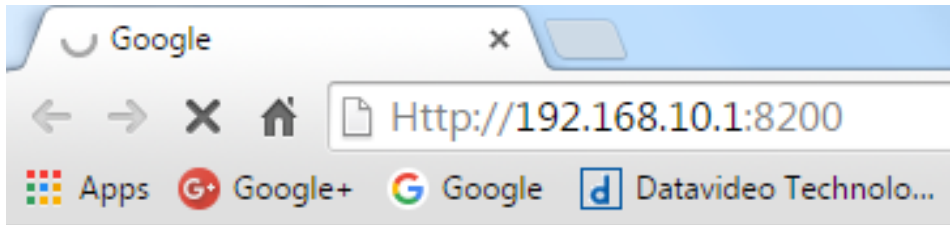

5. You will see the **dvPrompter Pro** application home page below.



6. To enter **full screen mode** press **F11** on the laptop keyboard.
7. Now turn to page 10 to learn how to set the laptop as either a Controller, Editor or Display device.

# Using DVP-100

## Home Page

The **dvPrompter Pro** home page is shown below. From here you can choose to turn your device into a controller, a prompter screen or a script editor.



Welcome to  
**dvPrompter Pro!**

To begin, click on one of the modules  
on the screen

---

Script playlist

The playlist is currently empty



### Use current device as a **CONTROLLER**



### Use device as a **PROMPTER SCREEN**



### Use the current device as a **SCRIPT EDITOR**



## Controller Page



Here you have control of script playback options on all connected prompter screens.

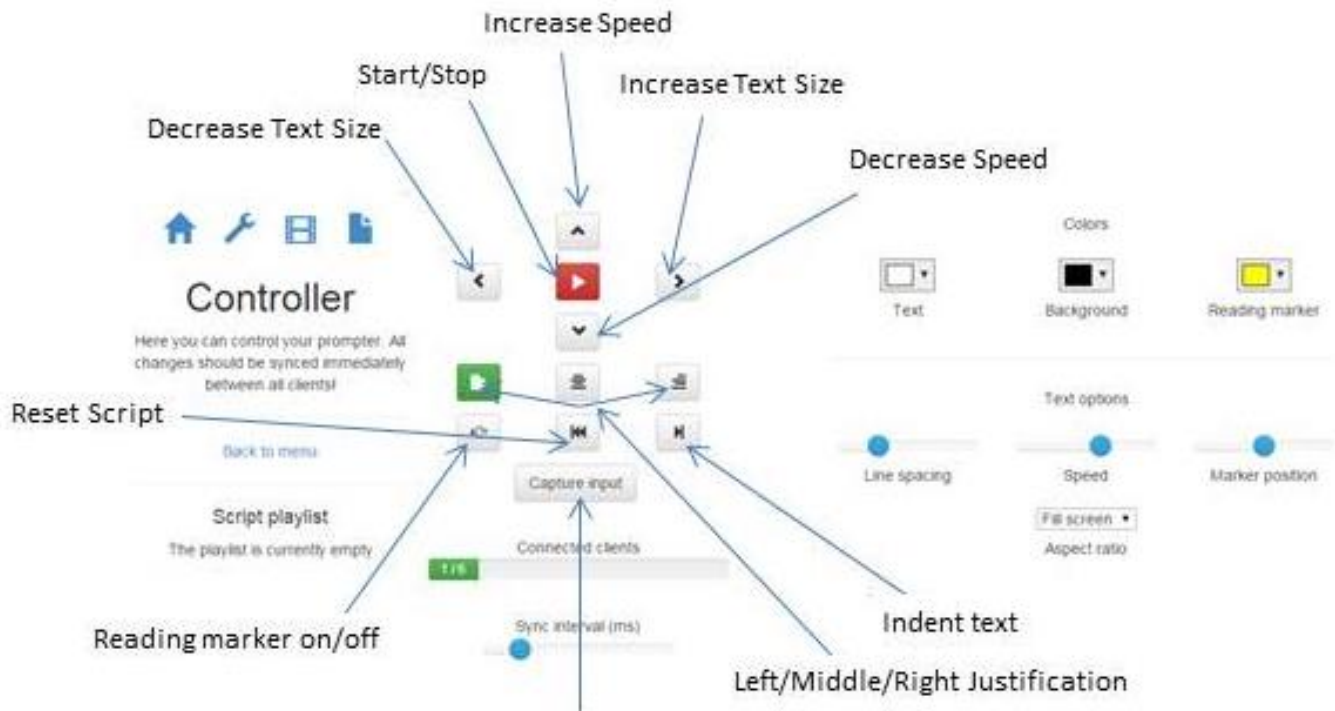

When enabled the controller listens for commands from a WR-450 remote



### Return to Home page

Clicking or tapping on the **Home icon** will return the device to the Home Page options again.

## Prompter Page



Devices set by this icon are prompter screens. These prompting devices **must have** the same screen resolution in order to stay in sync. The best way to do this is to make sure the devices used are identical units.

**Note:** Scrolling performance depends on the CPU and graphics performance of the device. The iPad 4 and above have adequate resources for smooth scrolling, Android devices may vary depending on specifications.

When using the DVP-100 iOS app this will automatically snap to full screen when in Prompting.

When using computer tablet based web browsers, the **F11 function key** is used to go to **full screen mode**.

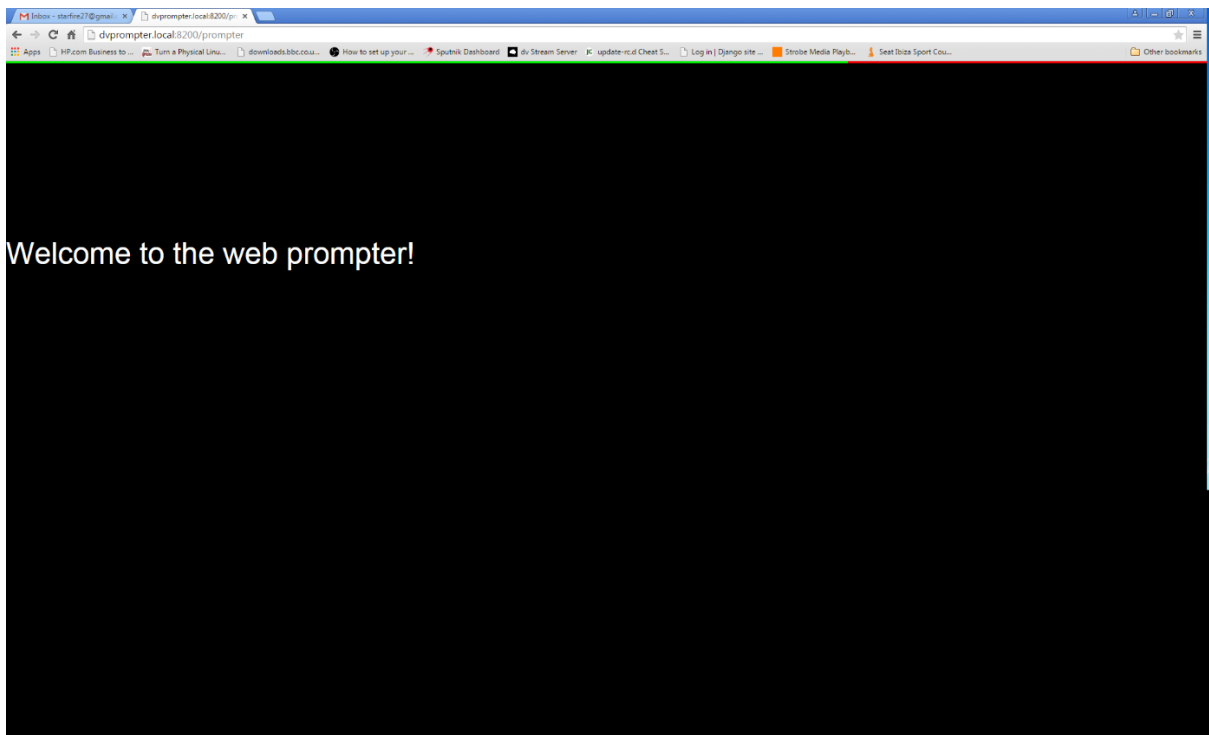

### Mirrored text view

Tapping or clicking once on the script will toggle the text scroll between Mirrored view and Normal view.

### Return to Home page

Double clicking or double tapping on the prompting screen will return the device to the Home Page options again.

### Script Control

Use a device in **Controller mode** or a compatible bluetooth remote, such as the WR-450, to control the script playback.

## Script Editor Page

Here you can load or create or edit scripts.



### Creating & Importing Scripts

You can create a script by typing directly into the rich text editor shown below or by importing files with the 'Choose File' button. Both simple text (.txt) and web (.html) files are supported.

### Editing Scripts

When a script is loaded into the dvPrompter Pro system and a change is made, that change will not be immediately reflected on the prompting screen(s) until the script is **saved** and re-loaded.

Title

Content

✂ 📄 📁 📁 📁 ↶ ↷ ABC **B** *I* U ~~I<sub>x</sub>~~ ☰ ☰ ☰ ☰ ☰ ☰ ☰ ☰ A A Font Size

body p

---

Realtime editing

Selecting a file will replace the contents of the editor

However, if the 'realtime editing' option is checked, any changes made in the text editor will be reflected in real time on the scrolling prompter screens.

## Loading Scripts

Once a script has been saved, you will be returned to the main scripts page.



# Welcome to scripts!

This is where your scripts are stored. Clicking on a script will offer you the options to edit it or to load it on your prompter!

[Create a new script](#)

[Back to menu](#)

## Script playlist

The playlist is currently empty

### News

UKIP's economic spokesman has insisted Nigel Farage is his "political hero" despite warning the UKIP leader had become a ...

### Sport

Liverpool boss Brendan Rodgers says he is not worried about his future at the club despite what some people see as a ...

### Weather

Mist and fog clearing, then plenty of further rather warm sunshine for many, but cloudier in the far north ...

Click or tap on the saved script that you wish to load.



## Script details

These are your script details. Feel free to change them any time!

[Load into prompter](#)

[Add to playlist](#)

[Delete script](#)

[Return to scripts list](#)

## Script playlist

The playlist is currently empty

Title

News

Content

UKIP's economic spokesman has insisted Nigel Farage is his "political hero" despite warning the UKIP leader had become a "snarling, thin-skinned, aggressive" man.

Patrick O'Flynn told The Times Mr Farage risked turning the party into a "personality cult".

But he said later he was not trying to launch a coup against Mr Farage and he wanted him to remain leader.

Mr Farage has said it is not his fault the party asked him to remain leader.

He stood down as party leader after failing to win the South Thanet seat in the general election, but was reinstated three days later when the party refused to accept his resignation.

body p

Update

Realtime editing

Selecting a file will replace the contents of the editor

Choose File No file chosen

To load the script into the prompter, click the '**Load into Prompter**' link and the script will load for playback.

## Playlist

On the previous page we saw how to select and load a script into the prompter. Alternatively you can add the selected script into a playlist of scripts. This feature allows you to create a possible running order of scripts.

Once a script is added to the playlist, it can be conveniently loaded from the controller page.

The screenshot shows the 'Script details' interface. On the left, there are navigation options: 'Load into prompter', 'Add to playlist' (highlighted with a red box), 'Delete script', and 'Return to scripts list'. Below these is a 'Script playlist' section with a list of scripts: 'Test', 'News', 'Sport', and 'Weather'. Each script has a set of four icons: a left arrow, a right arrow, a play button, and a red 'X'. A curved arrow points from the 'Add to playlist' button to the 'News' script in the playlist. The main area shows a 'Content' editor with a title 'News' and a text area containing a news article snippet. Below the editor is an 'Update' button and a 'Realtime editing' checkbox. At the bottom, there is a 'Choose file' button and the text 'No file chosen'.

When looking at the playlist, each icon to the right of a script has a different function.

Using the first two icons allows the script to be moved up or down the running order. The third icon allows playback of the selected script on the prompting devices. The x icon removes the selected script from the playlist but does not delete it.

Four examples of the 'Script playlist' are shown, each with a different icon interaction:

- Example 1: The 'News' script is highlighted with a red box.
- Example 2: The 'News' script is highlighted with a red box, and a red arrow points to the left arrow icon.
- Example 3: The 'News' script is highlighted with a red box, and the text 'Text script removed' is displayed below it.
- Example 4: The 'News' script is highlighted with a green box, and the text 'Play News Script' is displayed below it.

## Network Administration / Software Updates

Network administration and software updates can be accomplished by connecting to the unit's administration interface.

### Finding the DVP-100 device IP address

If you have connected the DVP-100 to an existing wired LAN but do not know its IP address you can find this DVP-100 IP address using the following procedure.

#### When using an Apple IOS device

1. First download the app titled 'DVP-100' from the Apple app store
2. Connect the IOS device to the same Wi-Fi network as the DVP-100
3. Open the DVP-100 app, it will scan the network and display the DVP-100 units detected in the '**Auto detected**' section.

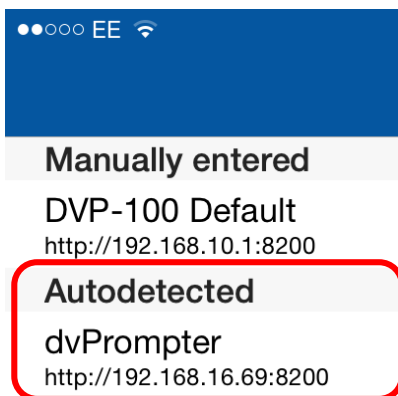

#### When using Mac OSX computer

1. Connect the OSX computer or IOS device to the same network as the DVP-100.
2. Open a web browser
3. Type <http://dvprompter.local> into the address bar and hit enter
4. You should be prompted to login (User: **admin** / Password: **000000**)
5. The device IP address will be displayed

#### When using Microsoft Windows computer

1. Connect the Windows computer to the same network as the DVP-100. Install the DVP-100 Finder software – available from [www.datavideo.com](http://www.datavideo.com)
2. Click scan from within this software
3. Then click on the device displayed to open the DVP-100 in the default web browser.
4. When prompted login (User: **admin** / Password: **000000**)
5. The device IP address is also be displayed.

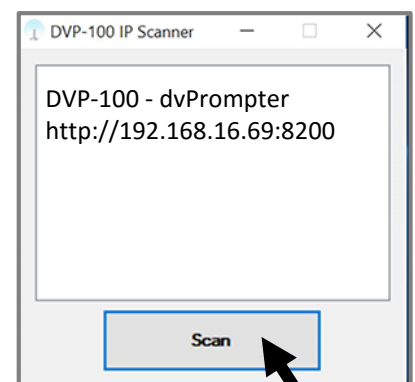

**Please Note:** If you cannot connect to the DVP-100 after changing the IP network settings you may need to use the physical reset on the unit to restore back to the factory IP defaults.



## Connecting to the DVP-100 administration interface

1. The DVP-100 will create its own Wi-Fi hotspot network called '**dvPrompter**'.
2. Connect your devices to the '**dvPrompter**' Wi-Fi network
3. Once connected, type the unit's IP address into a web browser, by default this is **192.168.10.1**
4. You will be asked to login: the username is '**admin**' and the password is '**000000**'
5. Once login is successful, you will see the screen below.

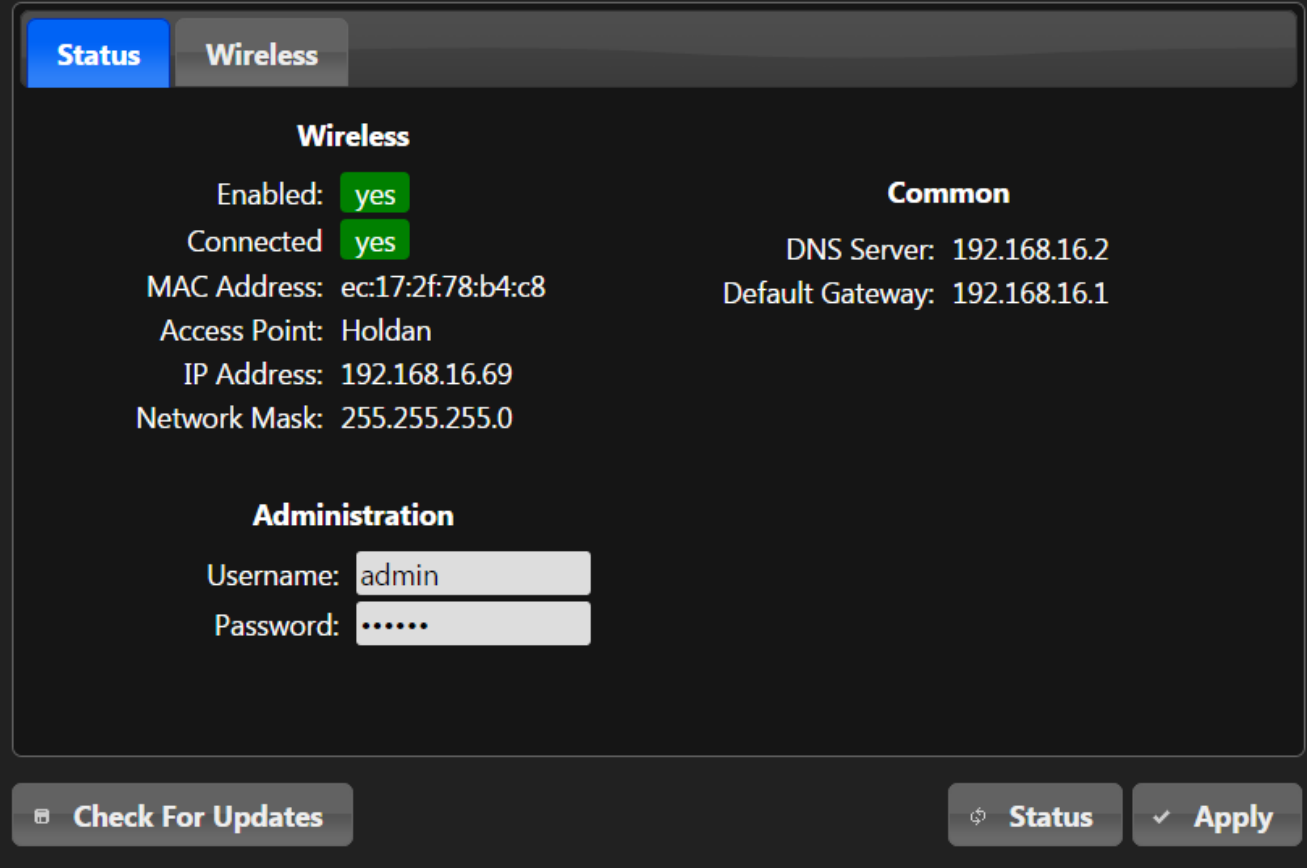

The screenshot displays the 'Wireless' configuration page of the DVP-100 administration interface. At the top, there are two tabs: 'Status' (highlighted in blue) and 'Wireless'. The main content area is titled 'Wireless' and is divided into three sections: 'Wireless', 'Common', and 'Administration'.  
- The 'Wireless' section shows 'Enabled: yes' and 'Connected: yes' in green boxes. Below this, it lists 'MAC Address: ec:17:2f:78:b4:c8', 'Access Point: Holdan', 'IP Address: 192.168.16.69', and 'Network Mask: 255.255.255.0'.  
- The 'Common' section lists 'DNS Server: 192.168.16.2' and 'Default Gateway: 192.168.16.1'.  
- The 'Administration' section contains two input fields: 'Username: admin' and 'Password: .....'.  
At the bottom of the interface, there are three buttons: 'Check For Updates' (with a refresh icon), 'Status' (with a refresh icon), and 'Apply' (with a checkmark icon).

## Changing Wi-Fi settings

To change the settings of the Wi-Fi interface, select the '**Wireless**' tab. By default, the device is in '**Access Point Mode**', and in this mode, you can select the Wi-Fi frequency and channel number as well as setting the DVP-100 device IP address.

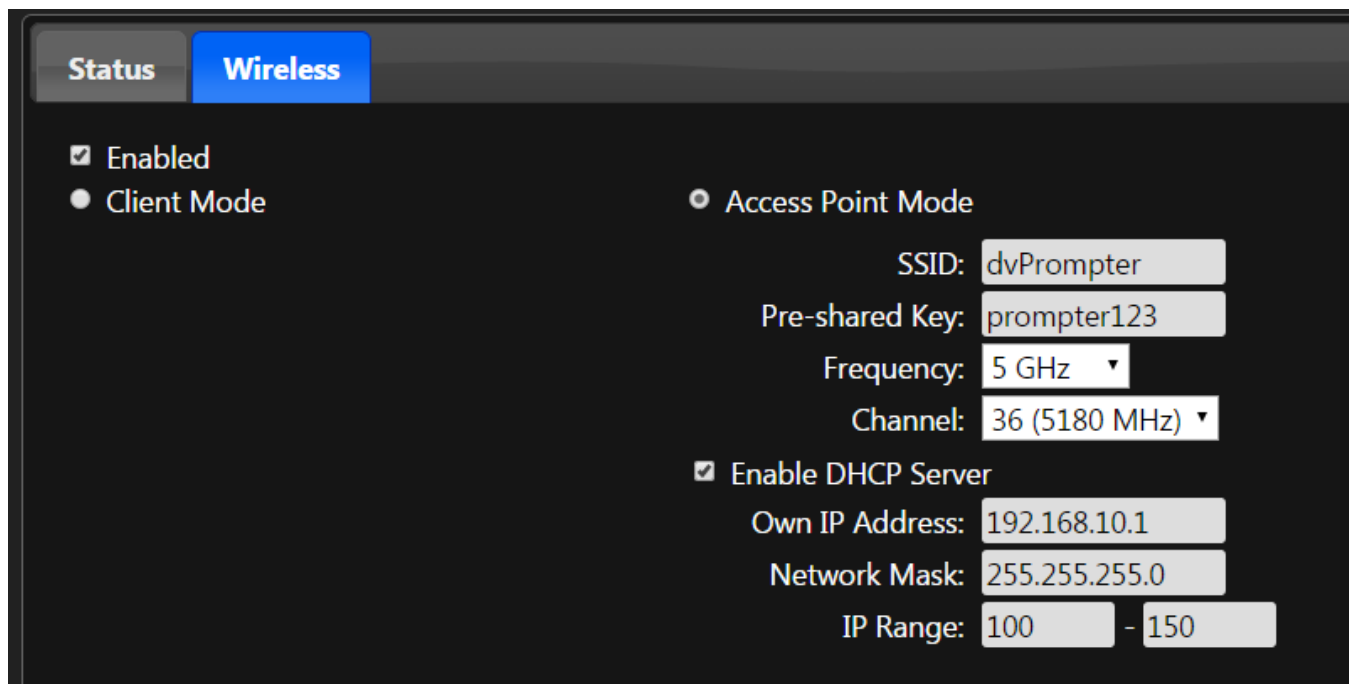

The screenshot shows the 'Wireless' settings page. At the top, there are two tabs: 'Status' and 'Wireless'. The 'Wireless' tab is selected. Below the tabs, there are two radio buttons: 'Client Mode' (unselected) and 'Access Point Mode' (selected). Under 'Access Point Mode', there are several fields: 'SSID' with the value 'dvPrompter', 'Pre-shared Key' with the value 'prompter123', 'Frequency' with a dropdown menu set to '5 GHz', and 'Channel' with a dropdown menu set to '36 (5180 MHz)'. There is also a checkbox for 'Enable DHCP Server' which is checked. Below this, there are three fields: 'Own IP Address' with the value '192.168.10.1', 'Network Mask' with the value '255.255.255.0', and 'IP Range' with two input boxes containing '100' and '150' separated by a hyphen.

To connect the DVP-100 to an existing Wi-Fi network, select **client mode** and enter your **network SSID** and **password**.

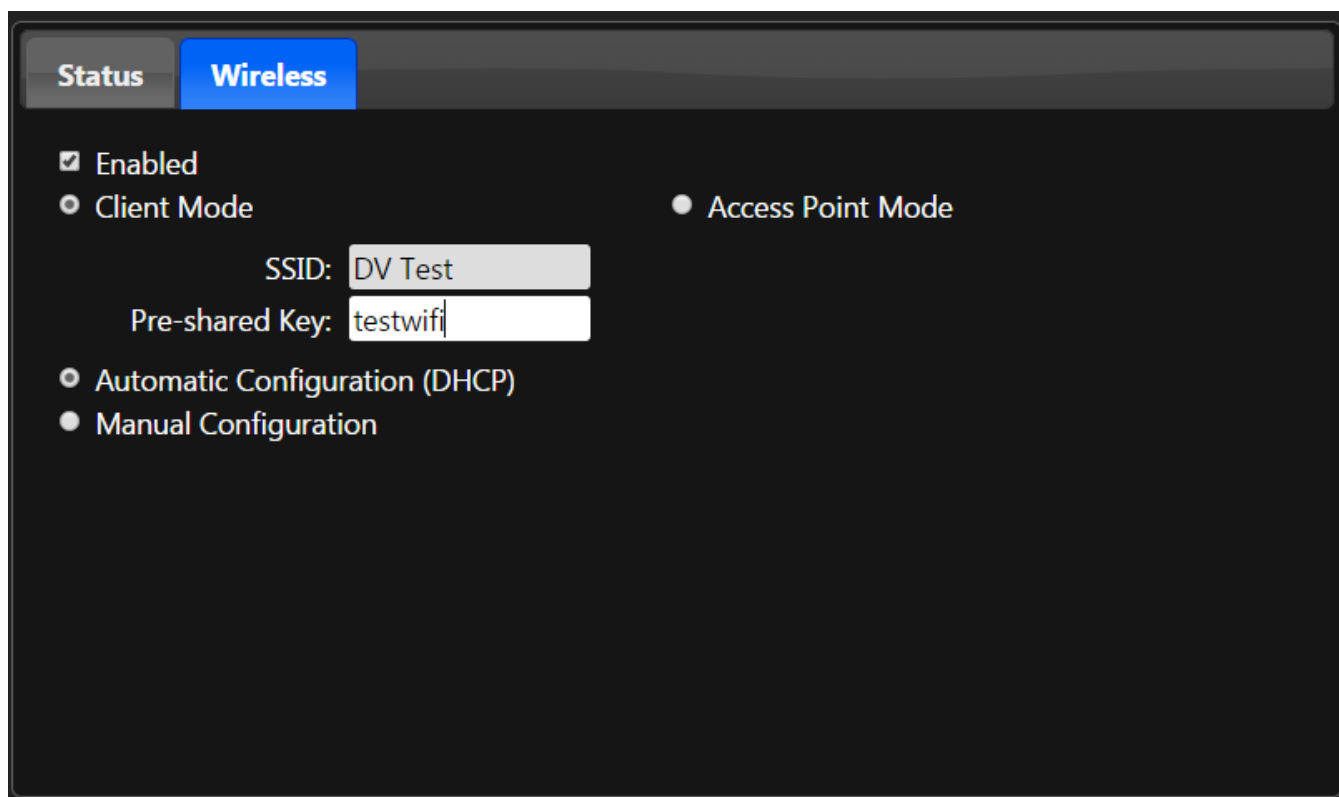

The screenshot shows the 'Wireless' settings page. At the top, there are two tabs: 'Status' and 'Wireless'. The 'Wireless' tab is selected. Below the tabs, there are two radio buttons: 'Client Mode' (selected) and 'Access Point Mode' (unselected). Under 'Client Mode', there are two fields: 'SSID' with the value 'DV Test' and 'Pre-shared Key' with the value 'testwifi'. Below these, there are two radio buttons: 'Automatic Configuration (DHCP)' (selected) and 'Manual Configuration' (unselected).

## System updates

To check for updates, you must connect the DVP-100 to the internet. Switch the Wi-Fi to client mode and connect the device to your Wi-Fi internet connection. Click the 'Check For Updates' button, and if an update is available, you will be prompted to install it automatically.

## Factory Reset

To reset the unit to its factory configuration please follow the procedure below. Please note any stored scripts on the DVP-100 will not be deleted.

1. Power on the DVP-100 unit and allow 60 seconds for it to fully boot
2. Hold in the reset button on the case for 5 seconds and then release
3. The unit will reboot to its factory settings

## Frequently-Asked Questions

This section describes problems that you may encounter while using the DVP-100. If you have questions, please refer to related sections and follow all the suggested solutions. If problem still exists, please contact your local distributor or the service centre.

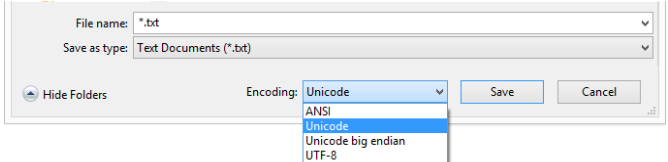
No.	Problems	Solutions
1.	<b>It was found that the prompter screens have different script running speeds.</b>	<p>Please note that the prompter screens must all be the same resolution in order to maintain sync. This is the same for all prompter systems.</p> <p>For example, all iPads from the iPad 3 retina onward use the same resolution so they will all stay in sync OK.</p>
2.	<b>Chinese texts in the text file are unreadable.</b>	<p>Please save the text file in Unicode format</p>  <p>The screenshot shows a file save dialog box with the following details: File name: *.txt, Save as type: Text Documents (*.txt), Hide Folders checkbox, Encoding dropdown menu open with options: Unicode (selected), ANSI, Unicode big endian, UTF-8, Save button, and Cancel button.</p>

## Dimensions & Weight

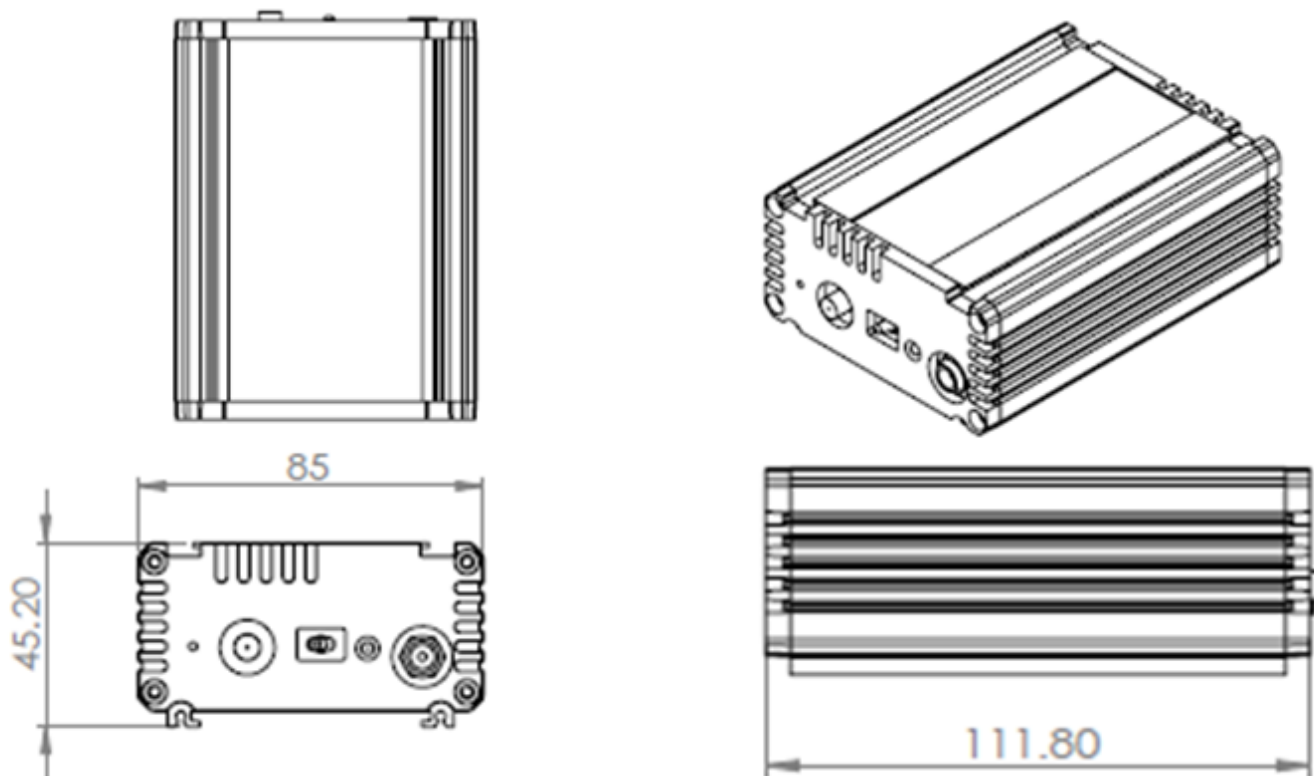

All measurements in mm

Unboxed Unit Weight: 0.37 Kg

Boxed Unit Weight: 0.6 Kg

## Specifications

<b>Interface</b>	DC IN Power LED Power Switch Antenna Reset Hole
<b>Network Feature</b>	Connectivity Technology : Wireless Frequency Band : 2.4 GHz / 5 GHz Protocol : IEEE 802.11n, IEEE 802.11g, IEEE 802.11b, IEEE 802.11a
<b>Control</b>	Web UI for system configuration and control
<b>Update</b>	Automatic firmware upgrade
<b>Power</b>	Input AC 100 ~ 240V Switching Adaptor Output DC 12V 1A
<b>Environmental Conditions</b>	Operating temperature: 0 ~ 50°C Storage temperature: -10 ~ 60°C



## Service & Support

It is our goal to make your products ownership a satisfying experience. Our supporting staff is available to assist you in setting up and operating your system. Please refer to our web site [www.datavideo.com](http://www.datavideo.com) for answers to common questions, support requests or contact your local office below.

### Datavideo Taiwan

Datavideo Technologies Co. Ltd  
10F. No. 176, Jian 1st Rd., Chung Ho  
District, New Taipei City 235, Taiwan,  
R.O.C.  
Tel: +886-2-8227-2888  
Fax: +886-2-8227-2777  
E-mail: [service@datavideo.com.tw](mailto:service@datavideo.com.tw)

### Datavideo Europe

Datavideo Technologies Europe BV  
Floridadreef 106  
3565 AM Utrecht,  
The Netherlands  
Tel: +31-30-261-96-56  
Fax: +31-30-261-96-57  
E-mail: [info@datavideo.nl](mailto:info@datavideo.nl)

### Datavideo United Kingdom

Datavideo UK Limited  
Units 1 & 2 Waterside Business Park  
Hadfield, Glossop, Derbyshire  
SK13 1BE, UK  
Tel: +44-1457 851 000  
Fax: +44-1457 850 964  
E-mail: [sales@datavideo.co.uk](mailto:sales@datavideo.co.uk)

### Datavideo USA

Datavideo Corporation  
7048 Elmer Avenue.  
Whittier, CA 90602,  
U.S.A.  
Tel: +1-562-696 2324  
Fax: +1-562-698 6930  
E-mail: [sales@datavideo.us](mailto:sales@datavideo.us)

### Datavideo China

Datavideo Technologies China Co  
101, NO.618, LiuYing Rd, Zhabei District,  
Shanghai, China  
Tel: +86 21-5603 6599  
Fax: +86 21-5603 6770  
E-mail: [service@datavideo.cn](mailto:service@datavideo.cn)

### Datavideo Singapore

Datavideo Technologies (S) PTE Ltd  
No. 178 Paya Lebar Road #06-03  
Singapore 409030  
Tel: +65-6749 6866  
Fax: +65-6749 3266  
E-mail: [sales@datavideo.sg](mailto:sales@datavideo.sg)

### Datavideo Hong Kong

Datavideo Hong Kong Ltd  
G/F., 26 Cross Lane  
Wanchai, Hong Kong  
Tel: +852-2833-1981  
Fax: +852-2833-9916  
E-mail: [info@datavideo.com.hk](mailto:info@datavideo.com.hk)

### Datavideo France

Datavideo France s.a.r.l  
Cité Descartes 1, rue Albert Einstein  
Champs sur Marne  
774477-Marne la Vallée cedex 2  
Tel: +33-1-60370246  
E-mail: [info@datavideo.fr](mailto:info@datavideo.fr)

### Datavideo India

Datavideo Technologies India Pvt L  
A-132, Sec-63, Noida-201307,  
Uttar Pradesh (UP), India.  
Tel: +91-0120-2427337  
Fax: +91-0120-2427338  
E-mail: [sales@datavideo.in](mailto:sales@datavideo.in)



Please refer to our website for update the latest  
version manual.  
[www.datavideo.com/Teleprompters/DVP-100](http://www.datavideo.com/Teleprompters/DVP-100)

**datavideo**  
www.datavideo.com

All the trademarks are the properties of their respective owners.

Datavideo Technologies Co., Ltd. All rights reserved 2018

Oct.10 2015 P/N: G082060762E1